

DIGITEL 1500

Part No. 1004964 Rev. I

Copyright © 1996
Physical Electronics, Inc.
6509 Flying Cloud Drive
Eden Prairie, MN 55344

Table of Contents

1 Introduction

1.1 Description	1-1
1.2 Specifications	1-2

2 Installation

2.1 Installation Procedure.....	2-2
2.2 Option Boards	2-4
2.2.1 Installing the Option Boards	2-5
2.2.2 Installing the Option Electrical Connections.....	2-10

3 Operation

3.1 Controls and Indicators	3-1
3.2 Operating Procedures	3-3
3.2.1 Ion Pump Operation	3-3
3.2.2 Display Operation.....	3-4
3.3 Rate of Rise Bargraph	3-6
3.4 Autorun	3-7
3.5 User Messages.....	3-8
3.6 Analog Outputs	3-10
3.7 Keypad Modes	3-10
3.8 CMD Functions.....	3-11
3.9 Setpoint Option	3-11
3.9.1 Parameter 1 (Setpoint).....	3-13
3.9.2 Parameter 2 (Hysteresis)	3-14
3.9.3 Parameter 3 (Control Parameter).....	3-15
3.10 Password Protection.....	3-16
3.11 Bakeout	3-18
3.12 Computer Interface Option	3-20
3.13 Summary of DIGITEL Commands	3-25

4 Service

4.1 Maintenance	4-2
4.2 Calibration.....	4-4
4.3 Troubleshooting	4-7
4.4 CMD Functions.....	4-9
4.5 Optional Accessory Equipment.....	4-10

5 Theory of Operation

5.1 Chassis (Schematic 1003230)	5-1
5.2 HV (High Voltage) Board (Schematic 1003228).....	5-2
5.3 Low Voltage Power Supply (Schematic 625703).....	5-2
5.4 CPU Board (Schematic 625463).....	5-2
5.5 Display Board (Schematic 1003223)	5-3
5.6 Keyboard (Schematic 1003219).....	5-4
5.7 Setpoint Board (Schematic 1003203)	5-4
5.8 Computer Interface (Schematic 1003227)	5-4

List of Figures

2-1 Rear Panel of the DIGITEL	2-2
2-2 Location of E501 and E502 on the HV Board	2-3
2-3 Location of Setpoint/Bakeout and Computer Interface Options.....	2-4
2-4 Location of Setpoint Connector	2-5
2-5 Installing the Setpoint Option Board	2-6
2-6 Location of Computer Interface Connector	2-7
2-7 Installing the Computer Interface Option Board.....	2-8
2-8 Rear Panel of Bakeout Power Distribution Box	2-9
3-1 Rear Panel Controls and Indicators.....	3-1
3-2 Front Panel Controls and Indicators.....	3-3
3-3 LED Display for CMD Functions	3-11
3-4 LED Display for Parameter 3 of Setpoint Option.....	3-15
3-5 Front Panel of Bakeout Power Distribution Box	3-18
4-1 Location of Maintenance Components	4-2
4-2 J405 and Safety Interlock.....	4-4
4-3 CPU Board Calibration Components.....	4-5
4-4 HV Board Calibration Components.....	4-6
4-5 Location of Troubleshooting Components.....	4-9

List of Tables

1-1	Specifications of the DIGITEL 1500	1-2
2-1	Setpoint Option Electrical Connections	2-10
2-2	Computer Interface Electrical Connections	2-11
3-1	Rear Panel Controls and Indicators	3-1
3-2	Front Panel Controls and Indicators	3-2
3-3	Pressure Conversion Constants	3-5
3-4	Error Messages	3-8
3-5	Status Messages	3-9
3-6	Setpoint Parameters	3-16
3-7	ASCII Conversion	3-20
3-8	Mode Commands	3-22
3-9	Computer Interface Error Codes	3-23
3-10	Computer Interface Keyboard Commands	3-24
4-1	Routine Maintenance Schedule	4-2

1 Introduction

1.1 Description

The DIGITEL™ 1500 is an ion pump power supply and system control. It accommodates ion pump sizes from 120 L/s. The high-voltage design provides ample current for larger ion pumps, but will limit power applied to a smaller ion pump. The AUTORUN feature determines optimum starting and running conditions for the pump size selected and then starts and monitors the pump without operator assistance. This feature also provides protection for the pump in case of overload conditions, power failures, ion pump malfunctions, or system malfunctions. The DIGITEL operates on 208/230 Vac, 50 or 60 Hz.

The DIGITEL is a programmable, microprocessor-based unit. The front panel digital display (shown below) provides direct readout of ion pump voltage, current, and pressure (torr or pascal). Ranging is automatic within the selected display mode. A **Rate-of-Rise** bargraph indicates the pressure trend in the system.

The keyboard controls all functions except main power and high voltage and includes optional features that allow you to customize the unit to a particular system.

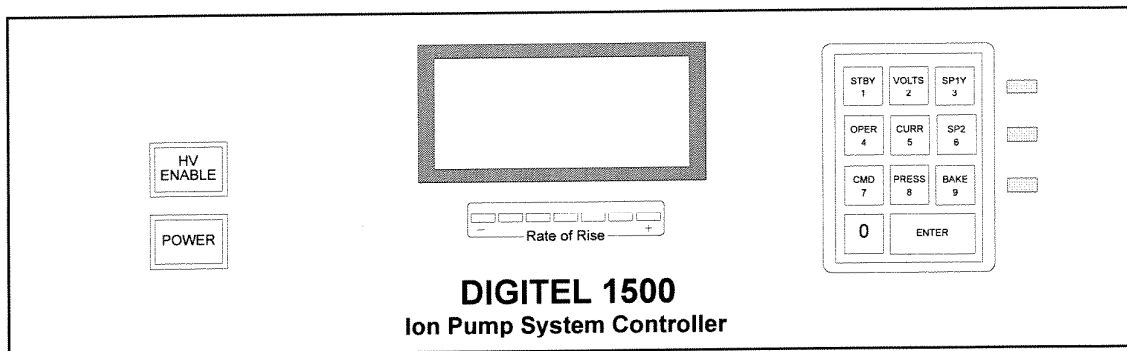

Options

A setpoint option provides two programmable setpoints, a dedicated setpoint if voltage goes below 2000V, and two remote inputs (standby and operate). The setpoint/bakeout option provides control over a complete system bakeout sequence with its own setpoint. A computer interface option allows information exchange with a host computer for remote control and log reports. Two analog outputs are provided for use with a data acquisition device or for leak detection.

1.2 Specifications

Table 1-1. Specifications of the DIGITEL 1500

Parameter	Specification
Rack mount	19 in. x 7 in. x 19.75 in.
Shipping weight; Unit weight	105 lb; 102 lb
Operating temperature	0 to 40°C. Free air flow around the unit is required.
Altitude	Sea level to 10,000 ft.
Humidity	0 to 80% RH (non-condensing)
Storage temperature	20 to 70°C
Input voltage	208 or 230 Vac \pm 10%. Selectable by internal jumper.
Line frequency	48 to 62 Hz. No adjustment necessary.
Power consumption	Idle: 50W; Operating: 250W typical; Max: 900W.
FUSE	10A slow blow 250V, 4A slow blow 250V. On rear panel.
HV output:	Internal jumper selects voltage at 6000V or 7000V.
Short circuit	750 mA at 60 Hz, at nominal line voltage.
Polarity	Positive. Can be converted to negative.
Analog outputs:	
Voltage	1V = 3333 V
Current	1V = 333 mA or 1V = 333 μ A (jumper select), 1 to 10V
Pump size	Selectable from rear panel (120 L/S or greater). Use pump size to calculate pressure and control max pump power.
Display:	7-segment red LED. 0.43 character height.
Voltage display	0000-9900V in increments of 100V.
Current display	0.0×10^{-6} to $5.1.0 \times 10^{-0}$ A. Autoranging.
Pressure display	1×10^{-9} to 1×10^{-4} torr, or 1×10^{-7} to 1×10^{-2} Pa. Autoranging. Units selected from the rear panel.
Rate-of-Rise bargraph	7 element bargraph indicates the rate of change of current.
Status display	Indicates display mode (volts, current, or pressure), setpoints $\frac{1}{2}$, bakeout status, power on, HV enable.
Computer interface (optional):	Baud rates: 150, 300, 600, 1200, 2400, 480, 9600.
RS-232/422 serial ASCII	7-Bit, 1 stop bit, even parity. No parity required on input.
Setpoints (optional)	Two user-adjustable SPDT setpoint relays with variable hysteresis and control parameter. Protected with a 4-digit code. One fixed setpoint activates at 2000V. EEPROM provides permanent setpoint storage for up to 10 years.
Bakeout (optional)	220V at 30A (resistive load) for main heater control.
Remote, Operate, Standby	Optically isolated, requires 12 to 30 Vdc pulse at 3 mA,

2 Installation

The DIGITEL™ 1500 can be mounted in a standard 19 in. (48.3 cm) rack or used as a free-standing unit. Specifications for the unit are found in Subsection 1.2.

Unpacking the unit

The unit is shipped in a special packing case (save it for reshipment). Carefully unpack the unit. Be sure all accessory items are removed. Compare the equipment received with the packing list to ensure that all items have been shipped. If there are any shortages, notify the carrier and PHI.

The following items are supplied with the unit:

- a 3-wire, detachable power cord
- mating connectors with each option
- a 15 ft. (457 cm) grounding wire
- a bakeout option is supplied with a cable

Inspect all items for damage. If damage is found, a claim should be filed with the carrier and a copy forwarded to PHI. Obtain authorization from PHI prior to return if the equipment is returned.

WARNING!

Before you install the DIGITEL, read the following:

- **Service should always be performed by qualified personnel.**
 - **Voltages up to 8000V are present. An interlock is provided to shut off power when the top cover is removed. Do not defeat this interlock.**
 - **Do not disconnect the high voltage cable with power on. After turning power off, allow at least one minute before disconnecting electrical equipment.**
 - **Do not operate the control without a proper electrical ground or near water. The control may be damaged and its safety reduced, if it is operated outside of its specifications.**
-

2.1 Installation Procedure

Input operating voltage

To convert operating voltage, an internal jumper must be changed. Only qualified personnel are allowed to change this jumper.

Note This unit can radiate radio frequency energy. Be sure that you install it according to instructions or interference could result. The unit protects against interference in a commercial environment. If operation in a residential area causes interference, it is the user's responsibility to correct this problem.

To install the DIGITEL, perform the following procedure.

1. Before making connections, make sure that the following items have been configured on the rear panel (Figure 2-1):
 - torr or pascal pressure readout is selected
 - ion pump size (both switches must be set to the correct size)See Subsection 3.2.2 to set the pump size.

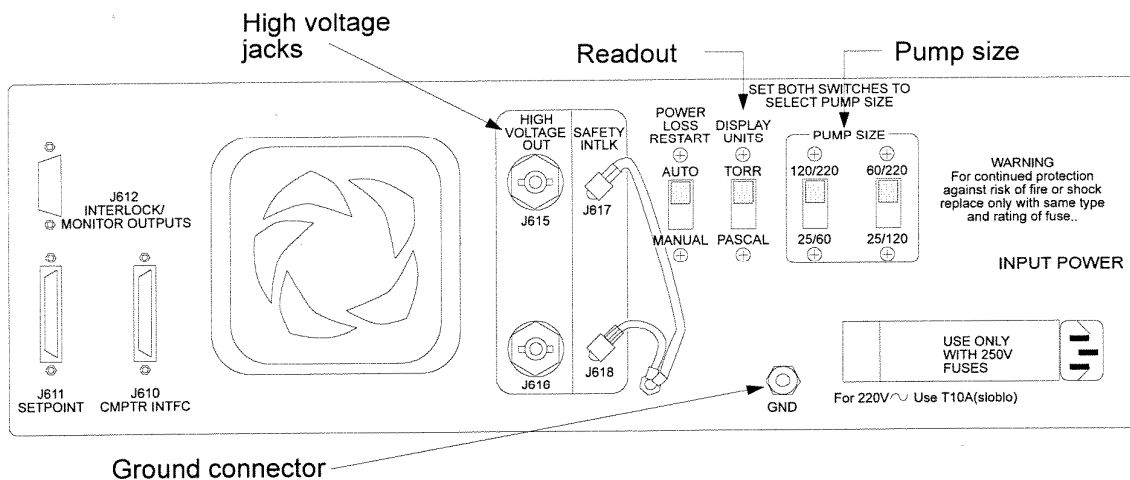

Figure 2-1. Rear Panel of the DIGITEL

2. Place the unit in its location and secure as necessary.
3. With power disconnected, connect the 15 ft. (457 cm) grounding wire between the pump and the safety ground at the rear of the chassis (Figure 2-1).

4. With power disconnected, connect the high voltage cable (not supplied) to the ion pump and to one of the high voltage jacks on the rear panel (Figure 2-1).

Note For negative output operation, the polarity must be changed. To do this, reverse the position of wires E501 and E502 on the high voltage (HV) board and solder them (Figure 2-2).

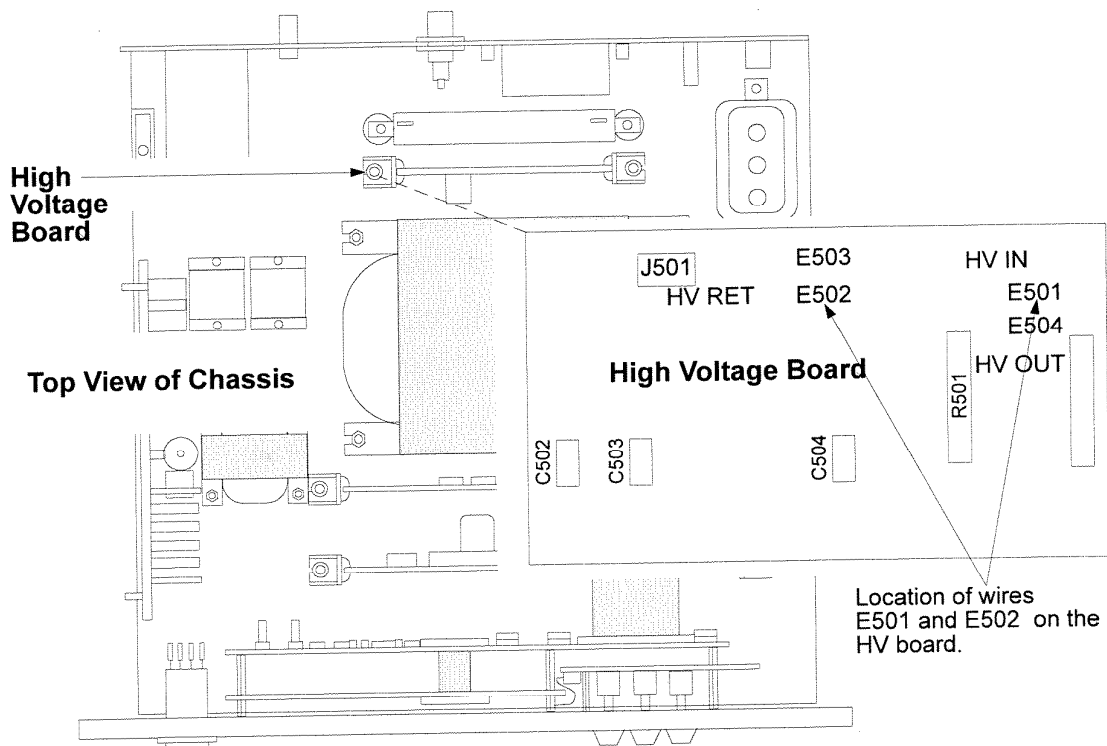

Figure 2-2. Location of E501 and E502 on HV Board

5. Connect the detachable power cord to input power on the rear panel and plug it into the wall.
6. Turn the unit on and verify the operation as described in Section 3.

2.2 Option Boards

Options are typically installed at the factory. If you need to install an option, read the following procedure before you begin. Figure 2-3 shows a top view of the chassis with options installed.

CAUTION!

Circuit boards may be destroyed by a small static discharge. To avoid damaging the boards, use the following precautions:

- **Handle boards at approved ESD workstation.**
- **Do not touch any electrical contacts.**
- **Do not rub a board against any insulator that may build up a static charge.**
- **When shipping boards, use approved ESD containers and packaging.**

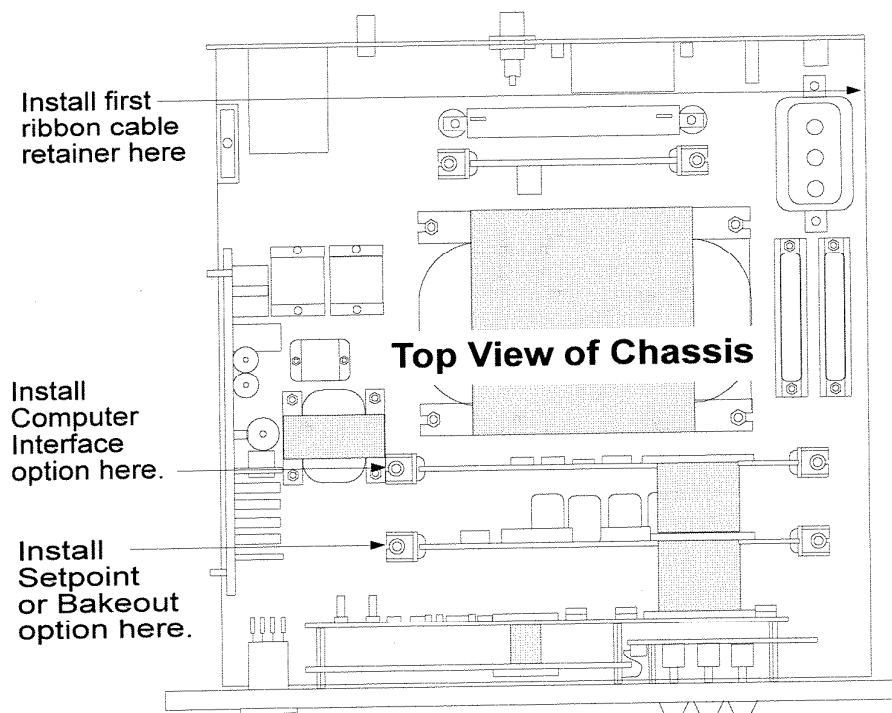

Figure 2-3. Location of Setpoint/Bakeout and Computer Interface Options

2.3.1 Installing the Option Boards

Before you begin

Perform this procedure before you install the options.

1. Turn the unit off and wait one minute to reduce high voltage to zero. Remove all connectors.
2. If rack-mounted, remove unit from the rack.
3. Remove the six screws attaching the top cover to the chassis and remove the cover.
4. Locate the mounting holes (drilled in the base of the chassis) for the card guides. Install two card guides for each option using the No. 6 hardware supplied.
5. Install two ribbon cable retainers on the rear side (Figure 2-3). Place one two in. (51 mm) from the rear panel and the other nine inches (229 mm) from the rear panel, both one in. (25 mm) from the bottom of the unit.

Setpoint option installation

Install the Setpoint Option board first. Use one of the following ribbon cables:

Installing the Setpoint Option only. Use the 2-position, short, 40 conductor ribbon cable so that it connects the CPU board and setpoint board.

Installing the Setpoint Option with the Computer Option. Use the longer 3-position ribbon cable so that it connects the CPU board, setpoint board, and computer interface board.

1. Install the male connector of the ribbon cable through the J611 opening (Figure 2-4) from the inside of the unit, so that the colored stripe (Pin 1) is on top.

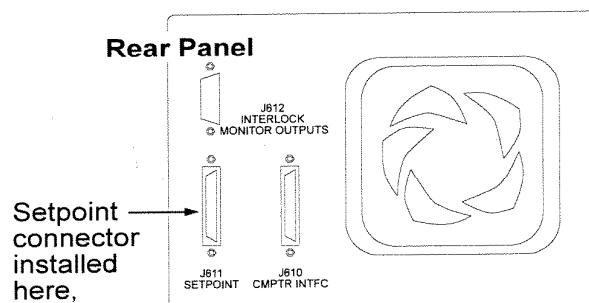

Figure 2-4. Location of Setpoint Connector

2. Holding the connector in place with one hand, insert the screwlock assembly in the mounting holes from the outside in. Attach a lock washer and nut to each of the screws on the inside of the unit and tighten each nut. Discard any remaining washers in the screwlock assembly kit.
3. Plug the other end of the ribbon cable into J711 on the setpoint board (Figure 2-5), matching the arrows and positioning the cable with the colored stripe on top.

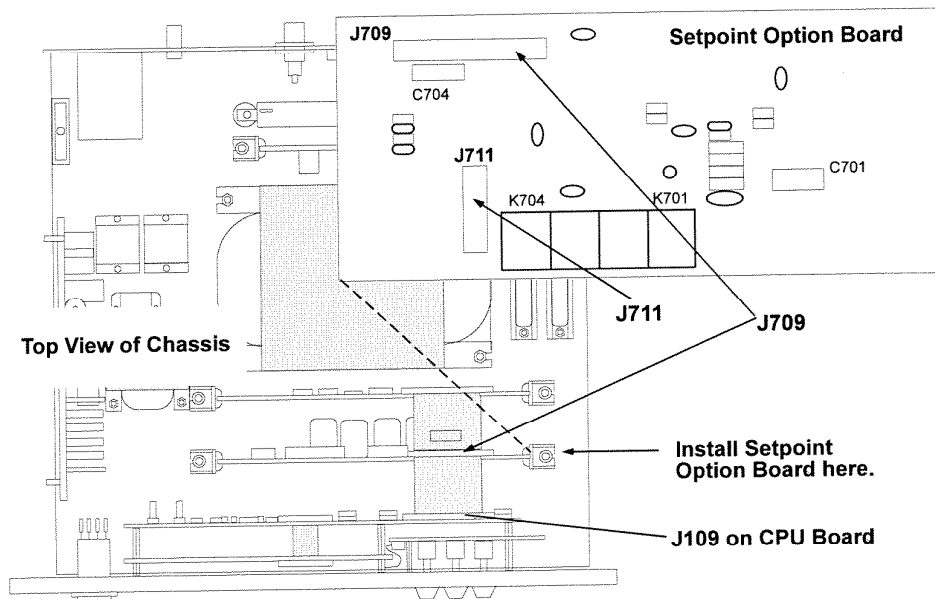

Figure 2-5. Installing the Setpoint Option Board

5. Install the board in the card guides so that the board components face the rear and the open connector is on top.
6. Put the ribbon cable in the guides on the side of the chassis.
7. **Installing the Setpoint Option only.** Plug the 2-position, short ribbon cable into J109 on the CPU board and J709 on the setpoint board (Figure 2-5) with the colored stripe (pin 1) closest to the left side of the chassis when the rear panel is facing you.

Installing the Setpoint Option with the Computer Option. The longer 3-position ribbon cable connects J109 on the CPU board, J709 on setpoint board, and J809 on the computer interface board (Figure 2-5). Pin 1 should be closest to the left side of the chassis when the rear panel is facing you.

*Computer
interface option
installation*

Install the Computer Interface Option board second. If this is the only option you are installing, insure that you perform Steps 1 through 5 in the *Before you begin* section. Use one of the following ribbon cables:

Installing the Setpoint Option only. Use the 2-position, short, 40 conductor ribbon cable so that it connects the CPU board and setpoint board.

Installing the Setpoint Option with the Computer Option. Use the longer 3-position ribbon cable so that it connects the CPU board, setpoint board, and computer interface board.

1. With the rear panel of the unit facing you, install the female connector of the ribbon cable through J610 opening (Figure 2-6) from the outside of the unit, colored stripe (pin 1) is on top.

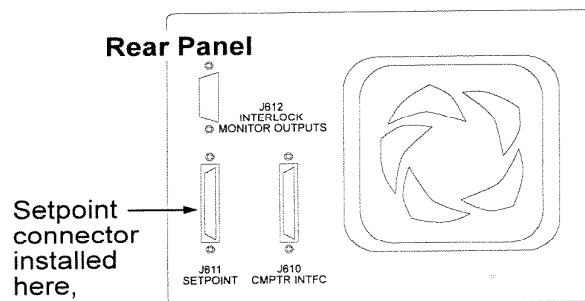

Figure 2-6. Location of Computer Interface Connector

2. Holding the connector in place with one hand, insert the screwlock assembly in each of the four mounting holes from the outside. Attach a lock washer and nut to each of the screws on the inside of the unit and tighten each nut.
3. Set the baud jumper (Figure 2-7). Install a jumper across the appropriate baud rate for your application.
4. Plug the other end of the cable into J810 on the computer option board (Figure 2-7), matching the arrows and positioning the cable with the colored stripe on top.
5. Install the board in the card guides closest to the rear panel so that the board components face the rear and connector J809 is on top.

- Put the ribbon cable in the guides on the left side of the chassis.

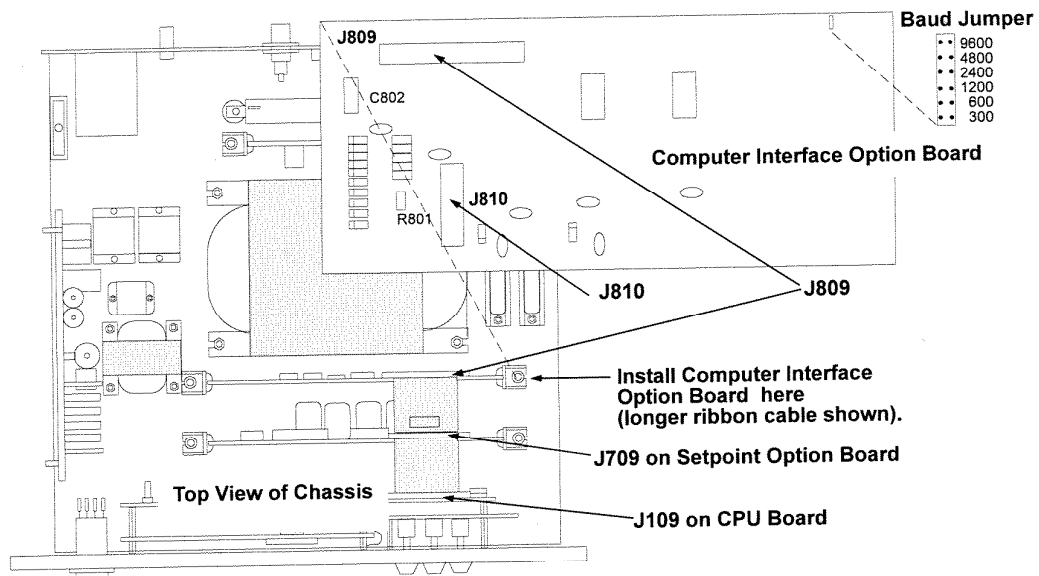

Figure 2-7. Installing the Computer Interface Board

- Installing the Computer Option only.** Attach the 2-position, ribbon cable connector into J109 on the CPU board and J809 on the computer interface board with the colored stripe (pin 1) closest to the left side of the chassis when facing the rear panel.

Installing the Computer Option with the Setpoint Option installed. If the 2-position short ribbon cable is installed on the setpoint board discard it. Plug the 3-position longer ribbon cable (supplied with the computer interface option) into J109 on the CPU board, J709 on the setpoint board, and J809 on the computer interface board (Figure 2-7). Pin 1 should be closest to the left side of the chassis when facing the rear panel.

After you have finished

Make sure all boards and connectors are seated properly. Replace cover with slotted holes toward front of unit. Replace six mounting screws.

Bakeout option installation

The Bakeout option consists of:

- a PC board that mounts in the DIGITEL
- a power distribution box

PC board

The PC Board is installed in the same way and the same place as a setpoint board. If the setpoint board is already in the unit, it must be removed and replaced with the bakeout board.

Power distribution box

The power distribution box connects directly to the DIGITEL and to a 230 VAC (30A) power source (Figure 2-8). It contains relay-controlled power outlets for bakeout, switched power outlets for pump power, and four outlets for non-interlocked power. With optional relay controlled outlet strips (3 maximum), the power distribution box can provide additional bakeout power and/or vacuum interlocked power for other equipment in the vacuum system.

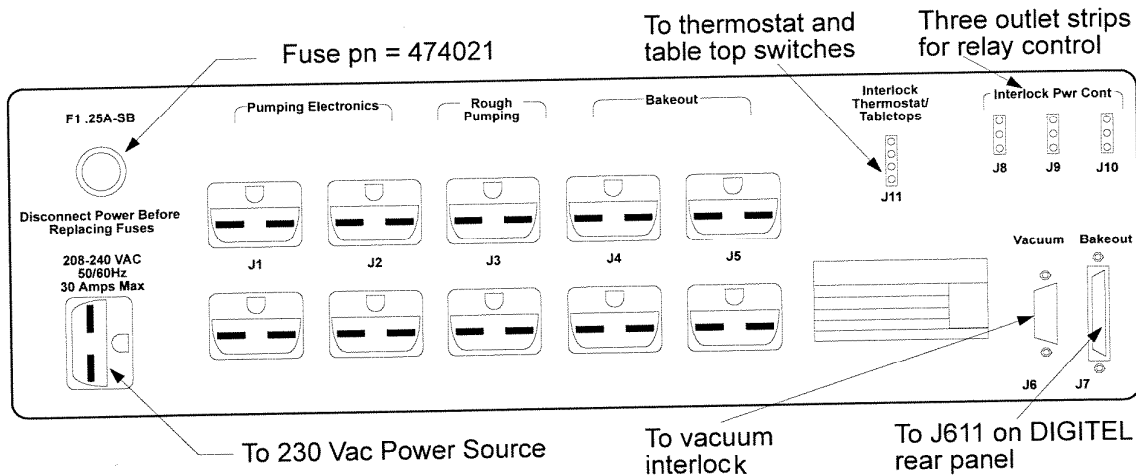

Figure 2-8. Rear Panel of Bakeout Power Distribution Box

2.3.2 Installing the Option Electrical Connections

Setpoint electrical connection

The setpoint board is connected through a 25-pin, male, sub-miniature D connector. The mating connector is supplied with the option, but is not wired due to the large variety of installation configurations that are possible. For each setpoint, there are three connections:

- NC (normally closed)
- C (common)
- NO (normally open)

When the setpoint is off, NC is switched to C. When the setpoint turns on, C is switched to NO and NC is open. The maximum current is 1A, and the voltage should not exceed 28V. The following table lists the electrical connections to the setpoint board.

Table 2-1. Setpoint Option Electrical Connections

Pin	Function
2	SP1 NC
9	SP1 C
1	SP1 NO
4	SP2 NC
11	SP2 C
3	SP2 NO
8	SP4 NC (fail-safe)
15	SP4 C
7	SP4 NO
23	STBY
10	OPER
22	CTL RETURN

STBY, OPER, and CTL RETURN lines remotely control the DIGITEL to the standby and operate modes. A +12 to +28V signal is placed between STBY and CTRL RETURN as appropriate.

Cable assembly

A shielded cable should be used when connecting to the DIGITEL. All pre-assembled cables provided by PHI are shielded. The cable should be assembled as follows:

1. Strip back the outer insulation of the cable to 1.5 in. (38 mm), exposing the shield.
2. Strip the shield back to 1/4 in. (6 mm) of the outer insulation.

*Computer
interface
electrical
connection*

3. Strip the insulation on the individual wires back 1/8 in. (3 mm).
4. Solder each wire to the solder cup side of each connector pin.
5. Install each of the pins in the appropriate position of the connector. The pins click into place. Once they are installed, they can only be removed with a special tool (not supplied).
6. Install the conductive housing. The housing should make good electrical contact with the cable shield and the connector.
7. Install the mounting hardware.
8. Attach the cable to the DIGITEL with the two mounting screws.

Electrical connection is made through a 25-pin, female subminiature D connector. The mating connector is supplied so that you can wire your own cable. Use only shielded cable. The maximum cable length is 50 ft. (15.2 m). This length may be increased in some cases if the baud rate is reduced or if a low-capacitance cable is used.

Normally, connection to three pins — TXD, RXD, and GND — is required. All signals are referenced to the DIGITEL. For example, TXD is the pin on which the DIGITEL transmits data. If a receive-only device is attached to the DIGITEL, such as a printer, only TXD and GND need to be used. The +12V and -12V signals are available for reference only. Do not use more than a few milliamps. Table 2-2 lists the interface connections.

If you do not require the break DETECT/RESET circuitry, clip Q801 to disable it from the circuit. Attach a note to the board stating why Q801 was removed. This will prevent the replacement of Q801 should the unit be returned for service.

Table 2-2. Computer Interface Electrical Connections

Pin	Description
1	GND
2	TXD
3	RXD
4	RTS (not used)
5	CTS (not used)
7	GND
8	DCD
9	+12v
10	-12V

3 Operation

3.1 Controls and Indicators

Controls and indicators are found on the rear and front panels of the DIGITEL™ 1500.

- Table 3-1 describes the rear panel controls. These components are identified in Figure 3-1.
- Table 3-2 describes the front panel controls. These components are identified in Figure 3-2.

Table 3-1. Rear Panel Controls and Indicators

Control	Description
Pump Select switch	Two switches select the pump size. Both switches must be set to the correct pump size
Display Units switch	Selects pressure display units of either torr or pascal. This switch also affects the operation of the setpoints.

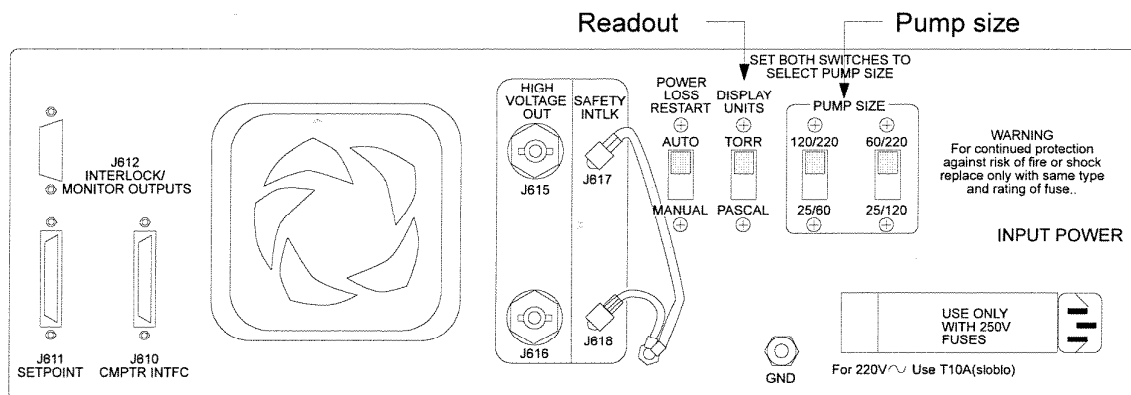

Figure 3-1. Rear Panel Controls and Indicators

Table 3-2. Front Panel Controls and Indicators

Control	Description
Power	Turns main power on and off. The switch is on and illuminated when it is flush with the bezel.
HV Enable	This switch is normally enabled (flush with the bezel). If it is off, high voltage cannot be generated. If enabled, it lights continuously if high voltage is on and flashes if high voltage is off.
Keypad	Used as the primary method for controlling the DIGITEL.
STBY	Places the DIGITEL in standby mode if high voltage is enabled. The HV enable indicator flashes.
OPER	Places the DIGITEL in operate mode if high voltage is enabled. The HV enable indicator lights continuously.
CMD	Used to enter special commands that control the computer interface, setpoint operation, and service features.
VOLTS	Places the display in voltage mode.
CURR	Places the display in current mode.
PRESS	Places the display in pressure mode. When this key is first pressed, the display momentarily flashes either torr or pascal to indicate the units displayed. The DIGITEL must be configured correctly for this mode to read properly (Subsection 3.2.2).
SP1, SP2, BAKE	These keys control the setpoint and bakeout operation. The indicators to the right of each key lights when that particular setpoint relay closes (Subsection 3.9).
0 through 9	The keypad is in the numeric mode if one of the display digits is flashing, otherwise it is in the command mode.
ENTER	Used to enter numeric data. If the bakeout option is installed, press this key while in command mode to momentarily display the number of hours remaining in the bakeout cycle.
Display	Displays the voltage, current, or pressure, as well as error and informational codes, setpoints and control parameters.
Rate of Rise	Gives an indication of the pressure trend within the vacuum system. Green lamps indicate a pressure decrease and red lamps indicate a pressure increase.

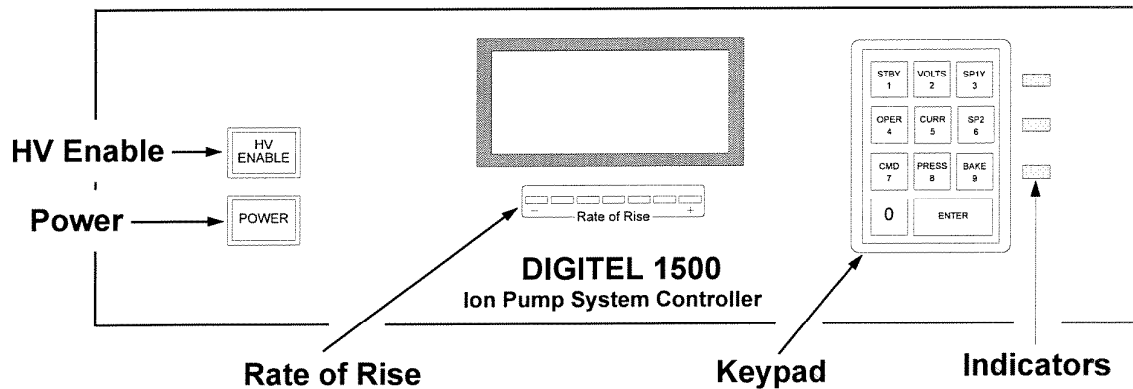

Figure 3-2. Front Panel Controls and Indicators

3.2 Operating Procedures

Overview

The following operating procedures are provided in this section.

- Ion Pump Operation
- Display Operation

3.2.1 Ion Pump Operation

Installation requirements

Before operating the ion pump, ensure that it has been installed according to instructions supplied with the pump. Install the DIGITEL according to the installation instructions in Section 2.

- Both the DIGITEL and the pump must be grounded and have a safety ground strap connecting them.
- The high voltage cable must be attached to the DIGITEL and the pump.
- The proper pump size must be selected.
- The DIGITEL must have the correct output polarity.

To evacuate the pump

Before you run an ion pump, it must be evacuated to a minimum vacuum. The details of this procedure are best obtained from the pump manual, but in general, the following procedures may be applied.

1. Valve off the ion pump from atmosphere.
2. Rough the pump down to 10 microns (1×10^{-2} torr) or less (generally, the lower the better).

3. Sorption pump roughing is highly recommended as contaminants do not backstream into the ion pump. If a mechanical pump is used, it must be well trapped or oil back-streaming from the mechanical pump can contaminate the ion pump.
4. If a pump is dirty or has been at atmospheric pressure, it may be necessary to bakeout the ion pump into the roughing pump before it can be started. This is done by heating the ion pump to a temperature of 150-250°C for a period of several hours.

To start the pump

1. Turn on power to the DIGITEL and press **HV ENABLE**.

After displaying *P-E* for two seconds,¹ the display shows OPER for one second. The **HV ENABLE** switch stops flashing and lights continuously when high voltage comes on.

2. When voltage starts to rise above 700V, the pump starts. The roughing pump should be valved off at this point. If the pump starts to stall when the roughing pump is valved off (as indicated by a decrease in voltage), the roughing pump should be valved back into the system. After voltage has increased above 3000V, the display may be switched to current or pressure to get a better idea of the ion pump pressure (when starting the pump, the voltage display mode is more sensitive to pressure changes at the high pressures).

3.2.2 Display Operation

Voltage mode When the DIGITEL is turned on, a *V* lights to indicate voltage display mode. To display voltage, press **VOLTS**. The display shows output voltage of 0000 to 9900 in steps of 100 volts.

Current mode To display current, press **CURR**. Current is displayed in scientific notation. The **x10** symbol lights to indicate scientific notation, and an *I* lights to indicate the current display mode.

Pressure mode To display pressure, press the **PRESS** key. The display briefly shows torr or pascl to indicate the display unit that has been selected.

¹ If this does not happen, see the Troubleshooting Guides to find out the problem.

Note Select the pressure display unit with the rear panel **Display Units** switch. For the display to read correctly, the pump size selection switches must both be set to the correct pump size.

At low pressures, the display may fluctuate considerably. This is a result of electrical noise in the ion pump.

*Setting the
Pump Size
switches*

Set the **Pump Size** switches to the pumping speed value closest to the pump's actual air speed. For example, if a 270 l/s pump is used, set the switches to 220 l/s position (left switch down and right switch up as viewed from the rear panel).

The accuracy of the pressure reading is dependent on line voltage, temperature condition and history of the pump. For example, as the pump ages, leakage currents develop and limit minimum pressure that can be measured. For this reason, pressure measurements should only be used as a general indication of pressure inside the vacuum system.

The pressure is calculated using the formula:

$$P_{\text{torr}} = 5 \times 10^{-3} \times I/N$$

where I is the pump current N is the number of pump elements.

- a 120 l/s pump has 4 elements
- a 220 l/s pump has 8 elements
- a 400 l/s pump has 16 elements
- a 700 l/s pump has 32 elements

To arrive at other units of measure, multiply P_{torr} by the correct conversion constant shown in Table 3-3.

Table 3-3. Pressure Conversion Constants

To convert From:	To:	Multiply by:
torr	pascal	133
torr	micron	$1 \times 10^{+3}$
torr	millibar	1.333
pascal	torr	7.5×10^{-3}
pascal	micron	7.5
pascal	millibar	7.5×10^{-2}
micron	torr	1×10^{-3}
micron	pascal	0.1333
micron	millibar	1.333×10^{-3}
millibar	torr	0.75
millibar	pascal	100
millibar	micron	750

3.3 Rate of Rise Bargraph

Indicators

The **Rate-of-Rise** bargraph determines the pressure trend within the vacuum system.

- When pressure within the system is constant, or changing slightly, the center yellow indicator lights.
- If pressure is decreasing, the green indicators light
- If pressure is increasing, the red indicators light

The number of green or red indicators that are lit, indicates the rate at which pressure changes. When high voltage is turned off through the microprocessor, the bargraph is shut off and reset to zero. When turned back on, it may take a few minutes for the bargraph to stabilize.

Leak detection

When a leak in an ion pumped system is probed with a gas such as helium, there is a slight change in pump current. The magnitude of this change is a function of the leak size, other pumps in the system, probe gas, operating pressure, and ion pump history. The general procedure for leak detection is:

1. Valve off portions of the vacuum system (if possible) until the section containing the leak is isolated.
2. Valve off all pumps except the ion pump (this is not possible if the gas load is too high).
3. Allow system pressure to stabilize.
4. Connect a digital voltmeter to **J612** on the rear panel, pins 7 and 1 (current monitor and ground, respectively).
5. Probe suspect area with helium while watching for a change on the meter.
6. When a change occurs, remove the gas.

CAUTION!

An excessive amount of helium in the vacuum system may cause the ion pump to stall since helium pumping speed is less than that of air. Probe large leaks cautiously.

3.4 Autorun

AUTORUN continuously monitors voltage and current and calculates the power applied to the pump in order to control ion pump operation. AUTORUN determines the size of the pump from the position of the rear panel pump size switches and can then determine how much heat the pump can dissipate. This information (power in, power out) is used to calculate the temperature of the pump elements.

Pump temperature

Pump temperature is important because:

- ion pumps can be damaged by excessive element heating
- as the temperature of the elements increases, the rate of outgassing increases, and causes thermal runaway if this rate is high enough

Cool-down mode

When pump temperature becomes too high, AUTORUN forces the DIGITEL into cool-down mode. It turns power off and lets the elements cool to reduce the outgassing to an acceptable level, then turns the pump back on.

AUTORUN also forces the DIGITEL into cool-down if it detects thermal runaway. If the voltage is between 1000 and 3000V and drops rapidly (as would happen if the pump went into thermal runaway while starting), the DIGITEL immediately enters the cool-down mode regardless of calculated element temperature.

While in the cool-down mode, the message *COOL* is displayed, and high voltage is off. After five minutes, high voltage automatically turns back on and the DIGITEL starts the pump again. If the DIGITEL cannot get the pump operating after four cool-down cycles, it shuts the pump off and displays *Err 5*. This indicates that a problem exists and care must be taken when operating the pump.

The run/cool cycle limit count is reset to zero whenever power is turned on, the **OPER** button is pressed, or after the pump has operated at 5×10^{-6} torr or less. The cool-down cycle may be aborted, and high voltage reapplied by pressing the **OPER** key.

Power failure

AUTORUN restarts the pump after power failure if the **HV ENABLE** switch is on.

3.5 User Messages

Error messages When error messages appear, they are in the form of *Err nn* where *nn* is the error number. For example *Err 2* means that the required option is not installed. Table 3-4 lists the error messages.

Table 3-4. Error Messages

Error	Description
1	Invalid function. Check manual and try again. (Some combinations of invalid CMD numbers may result in a meaningless command, in which case no error message is displayed and no change takes place.)
2	Required option not installed or there is a malfunction on the option board. In this event, contact your customer service representative.
3	When displayed, high voltage is off. You need to press the operate key or turn power off and back on to restart the pump. The DIGITEL does not recognize when the HV Enable switch is turned off by the operator. It only recognizes the loss of high voltage. So ERROR 3 is normal display when HV Enable is switched off.
4	Internal logic error. Contact your customer service representative.
5	Cycle limit shutdown. Four cool cycles have occurred (Subsection 3.4), high voltage has been shut off, and the DIGITEL is waiting for operator intervention.
6	Invalid key. Normally occurs when the <i>O</i> key is pressed while in the function mode.
8	Unable to write to EEPROM. A change to the setpoints, bakeout or password was made and the DIGITEL was unable to store it in nonvolatile memory. The setpoints may still operate but will fail to operate properly after power is turned off and back on again. If this occurs, contact your customer service representative.
9	EEPROM data invalid. This error occurs when the DIGITEL is first turned on. It indicates that setpoint, bakeout or password information that was previously stored in the nonvolatile memory has been lost. Try to program the lost data (see Err #8).
11	Illegal code, command rejected. An attempt was made to change a locked setpoint or the password, but an incorrect password was entered. Try again. If the password has been lost, contact your customer service representative.
13	Keyboard disabled via the computer interface. Re-enable the keyboard and repeat the command. (In some systems, this is done intentionally to prevent an inadvertent change in the power supply status.) See the system operating guide.

Status messages

Status messages assist the operator in the operation of the DIGITEL. Most of these messages occur immediately after a function key is pressed. Table 3-5 contains the status messages and their meanings.

Table 3-5. Status messages

Message	Description
Stby	STBY button pressed. STBY command received from computer interface or the DIGITEL was placed into standby by the remote STBY input on the setpoint option. High voltage is shut off. This is a momentary display.
OPER	As above, except start or operate function is activated and high voltage is turned on.
torr	PRESS key pressed or the pressure display mode was entered from the computer interface. This indicates that torr units were selected by the rear panel Display Units switch. This message flashes momentarily and is then replaced by the pressure display.
PASCL	As above, except pascal units selected.
COOL	The DIGITEL has entered the cool-down mode (Subsection 3.4). As long as it is in cool-down, this message remains on the display. If any function is accessed which generates a message (except OPER), the message replaces COOL and is also permanent.
SP1	Message appears briefly after SP1 is pressed.
SP2	Message appears briefly after SP2 is pressed.
BAKE	Message appears briefly after BAKE is pressed.
P-E	Message appears briefly at power up and if a break has been transmitted to the computer interface to indicate that a cold start is being performed.
old	Prompt occurs when CMD 2000 is entered to alter the password. The DIGITEL is asking for the password currently in effect.
CodE	Appears during a CMD 2000 operation (see old above) to prompt the operator for the new password. It also occurs when a change is made to a protected setpoint. In this case, it is asking for the current password.

3.6 Analog Outputs

D connector **J612** on the rear panel provides the monitor outputs. The following pins can be used for voltage and current metering:

- Pin 8 measures voltage (and pin 1 measures ground)
- Pin 7 measures current (and pin 1 measures ground)

Voltage measuring

Ion pump voltage can be obtained by measuring voltage at pins 8, 1 and applying this formula:

$$V_{IP} = V_{MON} \times 3333$$

For example, if 2.4V is measured, ion pump voltage is 8000V.

Current measuring

To obtain ion pump current, measure voltage at pins 7, 1

and apply this formula when **monitor jumper W301** (located on CPU board) is installed:

$$I_{IP} \text{ (m A)} = V_{MON} \times 0.333$$

If 0.09V is measured, ion pump current is 30 mA.

or apply this formula when **monitor jumper W302** (located on CPU board) is installed:

$$I_{IP} \text{ (m A)} = V_{MON} \times 0.000333$$

If 0.09V is measured, ion pump current is 30 μ A.

If the power supply has been wired for positive output, the voltage monitor signal is positive, and current signal is negative with respect to chassis ground. If wired for negative, these polarities are reversed.

3.7 Keypad Modes

The keyboard has two modes of operation, function and numeric.

Function mode

The function mode is the normal mode. Whenever a key is pressed, its function is executed. For example, if the key marked **STBY 1** is pressed while in function mode, the DIGITEL goes to standby mode.

Numeric mode

When a function requires numeric input, the keypad is placed in numeric mode. The display shows a number with the left most 0 flashing. The flashing digit can be changed by pressing a numeric key.

For example, if **CURR 5** is pressed, the display would show 5000 with the second digit flashing. After three digits are input, the first digit (a five) flashes again indicating that it can be changed. In this way, it is possible to correct a mistake by repeating the sequence. When the desired number is shown, press the **ENTER** key to enter the number.

- In summary*
1. The keypad is in function mode unless a display digit is flashing.
 2. The flashing digit is changed when a numeric key is pressed.
 3. The number is entered by pressing **ENTER**.

3.8 CMD Functions

CMD functions control the service mode, change the password on the setpoint, allow control of the computer interface, and implement special features. Each CMD function consists of four digits (Figure 3-3). CMD functions are entered using the numeric mode as described in Subsection 3.7. See Subsection 3.13 for a list of CMD functions.

If the CMD mode has been accidentally entered, input a value of 0000 to exit it. This value has no effect on the system.

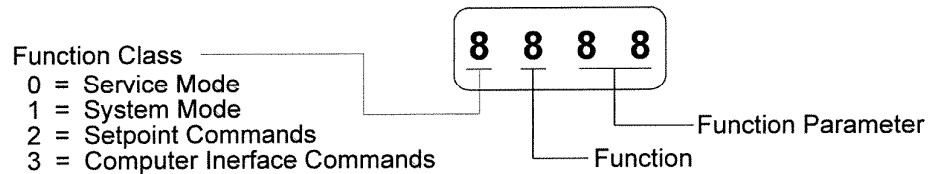

Figure 3-3. LED Display for CMD Functions

3.9 Setpoint Option

Setpoint allows you to control processor pressure-related functions. The three setpoints (two user adjustable and one fixed) have a set of NC (Normally Closed)/C (Common)/NO (Normally Open) contacts.

Note On **SPI & SP2**, the fourth digit is not used and must be set to 0. Please note that **SPI SP2** are independent. This means that you could program SP1 for pressure and password protection while SP2 operates on current and may be altered without a password.

Fixed setpoint

Typically the C contact in a fixed setpoint is switched to NC, but when output voltage exceeds 2000V, C switches to NO. This setpoint can be wired to an alarm, or system interlock to sound an alarm or shut the system down in the event of a pump malfunction. Note that C switches to NC if pressure is excessively high, pump or high voltage electrical system short circuits, or the DIGITEL fails to generate high voltage because of a failure, standby command, or loss of main input power.

*Adjustable
setpoints SP1
and SP2*

The two user adjustable setpoints, SP1 and SP2, operate identically, but are completely independent. Their purpose is to open or close relay contacts as a function of calculated system pressure in units that are selected for display on the front panel or by actual pump current. Using ion pump current to control setpoints is convenient if the DIGITEL is switched between different pressure measurement units.

The relay can control valves, heaters, chart recorders, interlocks, alarms, or other system functions. For example, you may want to open a valve and start a chart recorder when the pressure falls below 1×10^{-8} torr, and sound an alarm and shut down an electron gun if the pressure exceeds 5×10^{-6} torr. The rule for the control of the relay is that C is switched to NC except when pressure is less than the setpoint, at which time C switches to NO and the red lamp immediately to the right of the appropriate setpoint key lights. When this happens, the setpoint is on. Note that the setpoint is off if power is off, if high voltage is off (see Subsection 3.9.3 for the exception), if the pressure is higher than the setpoint, or if the setpoint is not active.

Note There is a difference between the terms *on* and *active*. *On* refers to the state of the relay. *Active* refers to whether the setpoint is enabled or not. If a setpoint is not active, it cannot be on.

Before a setpoint is operational it must be programmed with a setpoint value (parameter 1). Until this first parameter is programmed, or if its mantissa is zero, the setpoint is not active. Each setpoint consists of three parameters. The parameters are set using the numeric mode of the keypad as described for Parameter 1.

Parameters 1 and 2 have two digits that can be adjusted: the mantissa and the exponent. Each parameter has a range of 9.0×10^{-0} to 1.0×10^{-9} . If parameter 1 is set to 0.0×10^{-0} , the setpoint is not active. The third parameter consists of four digits, which may be set to 0 or 1.

Note When programming the DIGITEL, if you are not sure what something is for, set it to zero.

3.9.1 Parameter 1 (Setpoint)

The first parameter is the point at which the setpoint turns on (C contact of the relay switches to NO). If parameter 1 is set to 5.0×10^{-7} and the **Display Units** switch is set to torr, the setpoint turns on when pressure drops below 5.0×10^{-7} torr. If the **Display Units** switch is set to pascal, the relay turns on at pressures below 5.0×10^{-7} Pa. When pressure is 5.0×10^{-7} or higher, the setpoint turns off. To program the setpoint without hysteresis (with hysteresis, see Subsection 3.9.2.):

CAUTION!

While a setpoint is being changed, none of the setpoints respond to changes in pump current. If a setpoint is being used for an interlock, the interlock is temporarily disabled while the setpoint is being altered. It is therefore not recommended that the DIGITEL be left in this mode for a long.

1. Press **SP1**. The display flashes SP1 for one second and then shows the value of parameter 1. The first digit of the mantissa is flashing.
2. Press **5** to change the mantissa to 5.0. Note that the second digit of the mantissa is always zero. The exponent is now flashing.
3. Press **7** to enter the exponent value. The display now shows 5×10^{-7} , the desired value. The mantissa is flashing. Press **ENTER** to input the value.
4. The second parameter is now on display. If hysteresis is not desired, it should be 0×10^{-0} . If 0×10^{-0} is not displayed, press **0** twice to change it. Press **ENTER** to input this value.
5. The third parameter is now on the display. If hysteresis is not desired, then 0000 should be displayed. If 0000 is not displayed, press **0** four times to change it. Press **ENTER** to input the value.
6. The setpoint is now active and the DIGITEL returns to the previous display mode.
7. If the setpoint has been protected with a password, the password must be entered at this time. See Subsection 3.10.

The setpoints may be examined at any time by pressing **SP1** (or **SP2**), **ENTER**, **ENTER**, **ENTER**.

3.9 .2 Parameter 2 (Hysteresis)

The second parameter controls setpoint hysteresis. In many cases, it is undesirable to have a function turn on and off at the same point regardless of system history. For example, imagine a vacuum system in which an electron gun is operated only below a given pressure. Using the previous example, the setpoint is programmed to turn on at 5×10^{-7} and thus activate the gun.

A typical operating sequence for this system may be:

1. System pumps down to below 5×10^{-7} .
2. The gun turns on, outgassing, and raises the pressure to 6×10^{-7} .
3. The gun turns off, outgassing decreases, and the system drops to below 5×10^{-7} .
4. The gun turns on, outgassing, and raises the pressure to 6×10^{-7} .

By not having any hysteresis on the setpoint, a large oscillator has been built out of the vacuum system and the electron gun.

If parameter 2 is non-zero, it determines the point at which the setpoint turns off, while parameter 1 still determines the point at which the setpoint turns on. For example, with parameter 1 at 5×10^{-7} and parameter 2 at 7×10^{-7} , a typical operating sequence may now be:

1. System pumps down to below 5×10^{-7} .
2. The gun turns on, and the system pressure rises to 6×10^{-7} . Since the pressure has not reached the value of parameter 2, the setpoint remains on and the gun remains energized.

3.9.3 Parameter 3 (Control Parameter)

A third parameter determines how the setpoint functions. It consists of four digits, each of which has a value of 0 or 1 (Figure 3-4). Each digit has a specific function associated with it, which is controlled by the digit's value. For example, the first (left) digit determines if parameters 1 and 2 are to be compared against current or pressure. If the value is 0, the parameters are compared against pressure, and if 1, against current. The previous examples have all used the pressure mode, but this value could easily be set to 1 for ion pump current.

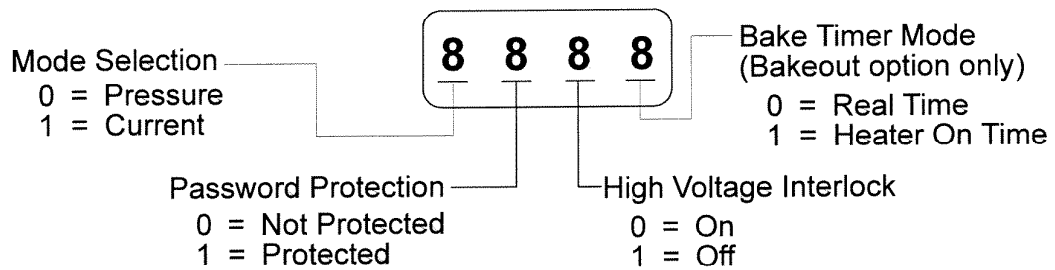

Figure 3-4. LED Display for Parameter 3 of Setpoint Option

This option is most useful where the preprogrammed current-to-pressure conversions in the DIGITEL are not appropriate for the pump you are using. Also note that if you change this parameter, it will most likely be necessary for you to change parameters 1 and 2 as well.

The second digit is used for password protection. When this digit is 1, the user is required to enter a four digit number before any change can be made to the setpoint. See Subsection 3.10 for more information.

The third digit controls the high voltage interlock, which is required because ion pump current decreases as pressure decreases. The problem arises when high voltage is shut off. With no voltage applied to the pump, the current is zero and the setpoints assume that the pump is at an extremely good vacuum when, in fact, the pressure could be quite high. For this reason, a high voltage interlock is invoked whenever the third digit is 0. When high voltage is shut off, the setpoint is shut off. Normally this is always set to 0. There may be times, however, where this interlock gets in the way of a process control scheme. The interlock may be defeated in this case by setting the digit to 1. The setpoint either turns on or remains on when high voltage is turned off.

3.10 Password Protection

Each setpoint may be protected from change using a four digit password. Setpoints can be examined or changed, depending on the status of password protection. When password protection is invoked (see Figure 3-4), the setpoint may be changed using the password. The setpoint can be examined, but not changed, by anyone that doesn't know the password.

Table 3-6. Setpoint Parameters.

Parameter	Format	Description
1	$X.0 \times 10^{-Y}$	Primary setpoint control value. Setpoint is inactive if $X = 0$.
2	$X.O \times 10^{-Y}$	Hysteresis control. If $X \neq 0$, this parameter determines the point at which the setpoint turns off. Parameter 1 should be less in value than parameter 2.
3	ABCD	Control parameter A = 0 (pressure), 1 (current) B = 0 (no password required), 1 (password required) C = 0 (HV interlock enabled), 1 (disabled) D = 0 (not used, should always be 0)

When the setpoint is not under password protection, it can be changed any time by anyone. Password protection can be invoked for an unprotected password simply by changing a digit in parameter 3 (see Figure 3-4). It is not necessary to know the password to invoke password protection.

However, the procedure to remove protection from a setpoint requires use of the password. If there is no record of the password necessary to remove the protection, contact your customer service representative.

To examine a protected setpoint, press:

SP1 (parameter 1)
ENTER (parameter 2)
ENTER (parameter 3)
ENTER

If changes have been made to parameters, a *CodE* is displayed, which requires you to enter the password. When you have entered the correct password, press **ENTER**. At this time the digit stops flashing, and the DIGITEL enters its normal mode. If an incorrect password is entered, the display momentarily shows *Err 11*, and the setpoint remains as it was before. To remove password protection on **SP2**, the procedure is:

SP2	(parameter 1)
ENTER	(parameter 2)
ENTER	(parameter 3)
00	(set digit #2 to 0) (password, display shows CodE)
ENTER	(enter the correct four digits of your password)

The change would now be in effect. All units shipped from the factory are preprogrammed with password 0000.

Note The password is required for changing any protected setpoints or the password itself. When changing the password, follow the steps carefully and **be sure to record the new password**. If the password is lost, contact your customer service representative.

A password is changed by entering a CMD function 2000. The display then shows *old*, requesting the old (current) password. If the correct password is entered, the display shows *CodE*, requesting the new password. This number becomes the new password. If the old password is incorrectly entered, the display momentarily shows *Err 11*, and the command is terminated. To change password of 0000 to 1234, the procedure is:

CMD	Enters the command mode.
2	The command number is 2000. ²
ENTER	Executes the command.
0000	The display of the old password is all zeros.
ENTER	The old password is entered.
1234	Inputs the new password.
ENTER	The new password is now in effect.

²Note that you need only enter the 2 since the remaining digits are already zero.

3.11 Bakeout

Description The bakeout option adds a setpoint to control vacuum system bakeout heaters. Bakeout is required to boil off molecules of a gas that are either in or on system components to obtain required system pressure.

Power distribution box The bakeout option includes a power distribution box with front panel controls and indicators. The following table describes the controls and indicators shown in Figure 3-5.

Emergency Off switch	Allows you to quickly shut down the system in case of emergency.
S2 switch	This switch is for vacuum bypass
S3 switch	When you turn this switch on for rough pumping, its associated indicator lights.
CB1, CB2, and CB3 circuit breakers	CB1, CB2, and CB3 are used for Bakeout , Pumping Electronics , and Main Power , respectively.
Bakeout and Main Power indicators	The Bakeout indicator lights when bakeout is on. The Main Power indicator lights when main power is on

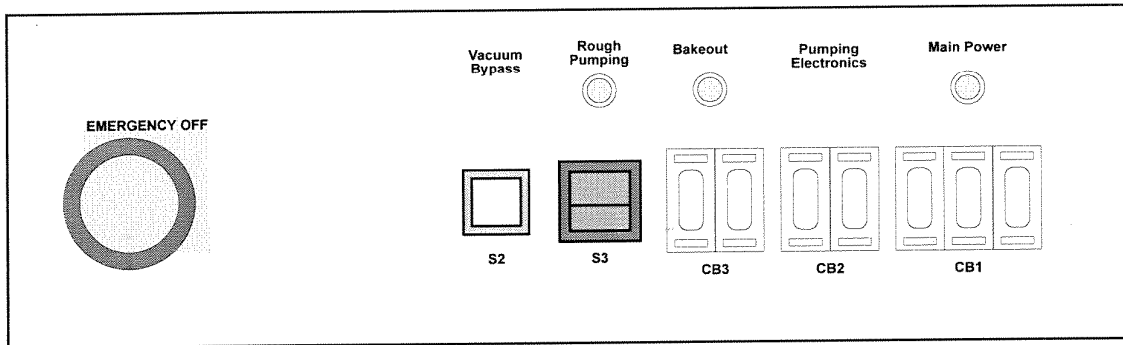

Figure 3-5. Front Panel of Bakeout Power Distribution Box

Bakeout procedure During bakeout, provisions must be made to limit temperature (to prevent damage to the system components), shut off heaters if pressure becomes too high (to prevent the gas load from stalling the pumps), and shut off the heaters after a preset time interval (to end the bakeout). Temperature limiting is done by sizing heaters to the system (watts in vs. heat loss) or by reversible temperature limit switches. Pressure limiting and timing is performed by the DIGITEL.

The **BAKE** setpoint operates like **SP1** and **SP2** (Subsection 3.9) except that a time (parameter 4) and activate control have been added. If parameter 4 is 0, the timer runs continuously until the end of the cycle, and if 1, it runs while the heaters are on. The timer is adjustable from 1 to 99 hours. The following example programs the heaters to turn on at 1×10^{-6} , turn off at 5×10^{-6} , sets the time run while the heaters are on, and sets the timer for 32 hours:

BAKE	Puts the DIGITEL in bakeout control mode. Displays <i>BAKE</i> .
ENTER	Displays the first parameter.
1,6	Sets parameter 1 (heaters turn on) to 1×10^{-6} . See Subsection 3.9.1.
ENTER	Enters the value and displays parameter 2 (when the heaters turn off). This is for hysteresis and is optional (Subsection 3.9.2).
5,6	Sets the value to 5×10^{-6} .
ENTER	Enters the value and displays the control number.
0,0,0,1	Sets the timer to run while heater is on. The three zeros configure the setpoint to pressure, no password, HV interlock enabled.
ENTER	Displays the value of the timer followed by Hr.
3,2	Sets the timer.
ENTER	Enters the time value. If the setpoint had been password protected, you are prompted for the password at this point.

The bakeout setpoint has been configured, but the heaters do not turn on until the sequence is started. To do this, press:

BAKE	Displays <i>BAKE</i> .
BAKE	Time is reset to its programmed value, and the heaters turn on if pressure is below the setpoint.

The lamp immediately to the right of the **BAKE** key lights when the heaters are commanded on.

To determine the number of hours remaining in the cycle press **ENTER** in the function mode. The display shows XX Hr (XX is the number of hours remaining) for two seconds and then resumes normal operation. The bakeout setpoint may be deactivated by accessing any of the three setpoints. For example, to deactivate the bakeout setpoint, press:

BAKE ENTER ENTER ENTER ENTER ENTER

3.12 Computer Interface Option

Table 3-7. ASCII Conversion

Character	Value (hex)	Character	Value	Character	Value
BS	0* (backspace)	5	35	L	4C
LF	oA (line feed)	6	36	M	4D
CR	OD (carriage return)	7	37	N	4E
PR	OE (print)	8	38	O	4F
SP	20 (space)	9	39	P	50
#	23	:	3A	Q	51
(28	A	41	R	52
)	29	B	42	S	53
*	2A	C	43	T	54
+	2B	D	44	U	55
-	2D	E	45	V	56
.	2E	F	46	W	57
0	30	G	47	X	58
1	31	H	48	Y	59
2	32	I	49	z	5A
3	33	J	4A		
4	34	K	4B		

Note ASCII characters can be strung together to form commands. ASCII commands are listed under CMD functions and Computer Interface Commands (See Subsection 3.13).

Transmission protocol

As each character is transmitted to the DIGITEL, it is echoed back to the device to verify that the character was received. The DIGITEL expects to receive 7-bit characters with one stop bit (parity is ignored). It transmits 7-bit characters with one stop bit and even parity.

Control characters

The computer interface uses two special control characters:

- Backspace [BS], sent to the DIGITEL, deletes the previous character. If there is no previous character (at the start of the line for example), the command is ignored (BS is not echoed).
- Print red [PR], transmitted by the DIGITEL, tells the printer to print a line of red text. PR occurs at the beginning of a line and indicates an exception report that occurred in autolog mode.

RD command

Use the read data (RD) command followed by CR to generate a report. The report is transmitted in the following format:

DDbHH:MMbXXXXVbX.XE-XIbHCB123

where:

- DD** is the day.
- HH** is the hour on the 24-hour clock
- MM** is the minute
- XXXXV** is voltage from 0000 to 9900
- X.XE-XI** is the current in scientific notation
- H** indicates high voltage is on. If not on, a '-' is sent instead.
- C** as above but indicates cool-down mode.
- B** as above but indicates the bakeout option is enabled.
- 1** as above but indicates setpoint 1 is on (the relay energized).
- 2** as above but indicates setpoint 2 is on.
- 3** as above but indicates the bakeout heaters are on.
- B** is a blank or space.

For example, the report 07 14:43 5900V2.6E-3I H-B1-3 tells us that it is day 7 at 2:43 P.M., the output is 5900V at 2.6 mA, the high voltage is on, bakeout is enabled, setpoint 1 and the bakeout heaters are on.

Note Voltage or current information is not updated while in cool-down mode.

RC command

Use the RC command to generate a report that lists AUTORUN parameters. The output format is:

XXPbXXIbXCbXS

where:

- XXP** is accumulated power (XX x 0.444 = watts x hours)
- XXI** is accumulated current (XX x 1.11 = milliamp x hours)
- XC** is cool-down cycle count. The counter starts at 4 and counts down each cool period. When 0 is reached, the HV is shut off and *Error 5* is displayed.
- XS** X is 1 for 25 1/s pump, 2 for 60 1/s, 4 for 120 1/s, 8 for 220 1/s pump.
- b** is a blank or space.

These values are related as follows. A pump is allowed to dissipate 34.4 watts per element on a continuous basis. If excess power above this value exceeds 3.56 watt-hours per element, the DIGITEL enters cool-down. The number of elements is determined from the 'S' parameter.

Example 1:

A 220 1/s pump is operating at 5100V, 19 mA. The power is 5100×0.019 , or 96.9W. $96.9/8 = 12.1$ watts per element. Since this is less than 34.4, the pump runs under these conditions indefinitely.

Example 2:

A 60 1/s pump is operating at the above conditions. The power per element is $96.9/2 = 48.5$ W/element. Excess power is $48.5 - 34.4 = 14.1$ W/elements. The power limit is reached in $3.55/14.1 = 0.25$ hours, or 15 minutes.

The P value can be used to determine how close the pump is to reaching power limit shutdown. These limits are shown in Table 3-9.

Pump Size	S Value	P Value
20-25	1	11
60-80	2	21
120-150	4	42
220-270	8	84

The current parameter works like power but it is not dependent on pump size. A value of 50 mA is used continuously. When 50 mA-hr of excess current has accumulated, the cool-down cycle is initiated.

Example

A pump uses 120 mA. Excess current drawn is $120 - 50 = 70$ mA. The cool cycle is entered due to excess current after $50/70 = 0.71$ hours or 43 minutes. This occurs when the I parameter reaches a value of 88.

Excess current and power parameters do not reset when the cool-down is entered, but slowly decrease as 50 mA and 34.4W, respectively, is subtracted from them.

Setpoint readout

The value of various setpoints can be read out. The format is:

- where X is:
- 1 for setpoint 1
 - 2 for setpoint 2
 - 3 for the bakeout setpoint

The output format is **X.OE-XbY.OE-YbZZZZbHH**

where:

- X.OE-X** is parameter 1
- Y.OE-Y** is parameter 2
- ZZZZ** is parameter 3
- HH** is parameter 4, the bakeout timer; only appears for the command RS3.

Mode control commands

Mode control commands are in the format **MX**

where X is a digit between 1 and 9 (Table 3-8).

Table 3-8. Mode commands.

Mode Command	Function
1	Standby
2	Operate
3	Display voltage (on LEDs)
4	Display current
5	Display pressure
6	Bakeout enable
7	Bakeout disable
8	Keyboard on
9	Keyboard off

These functions draw a close parallel to keyboard commands except on/off commands. If the keyboard has been turned off from the computer interface, pressing a key momentarily displays *Err 13*.

Setpoint control command

The setpoint control command format is **SNPXXYY**

where:

- N** is the setpoint number (1, 2 or 3)
- P** is the parameter number (1, 2, 3 or 4)
- XX** are the two digits of the parameter, or if the parameter requires four digits, **XXYY**.

Example 1:

The control parameter of setpoint 1 is set to 0010. The command is S130010.

Example 2:

The bakeout timer is set to 24 hours. The command is S3424.

Example 3:

Parameter 1 of setpoint 2 is set to 6.0×10^{-9} . The command is S2169.

If setpoint is not installed, these commands display ERROR #33.

S3 commands do not work unless the bakeout option is installed.

Table 3-9. Computer Interface Error Codes.

Err#	Description
20	Input buffer overflow-the entire line is lost.
30	Invalid command- command does not exist. Example: WB6MSC.
31	Invalid parameter (illegal character), example: letter entered instead of number.
32	Invalid parameter (illegal value). Example: 78 hours entered where the allowed range is 00 to 23.
33	Option not installed (M6 entered when bakeout option is not installed).

Logging control commands

Logging is controlled by commands in the format: **SLN**

where N has the following values:

- 1 Timed reporting on
- 2 Exception reporting on
- 3 Timed reporting off
- 4 Exception reporting off

The timed reporting interval is adjusted by the command **SLINN**:

where: NN = 01 to 99 minutes

The date and time may be set with the command **STDDHHMM**

where: DD is the day (00-99)
HH is the hour (00-23)
MM is the minute (00-59)

Timed and exception reporting generate the same output produced by the RD command. Timed reporting produces an output at fixed intervals that can be set from 1 to 99 minutes. Exception reporting generates an output when any of the setpoints change states or when high voltage is turned on or off.

When a command is received and executed, the DIGITEL responds with an * followed by a **CR**, **LF**. If the command produces an error, the error number is printed out in the format below:

ERROR #NN

The logging functions can also be controlled from the DIGITEL keyboard. The CMD function (Subsection 3.8) is used to enter all functions. Available functions are listed in Table 3-10. All but two (3005 and 3006) have equivalent computer interface commands. 3005

turns the computer interface off so that no commands are accepted and no reports are generated. 3006 reinitializes the computer interface just as if power had been turned off and back on again.

Table 3-10. Computer Interface Keyboard Commands.

Function	CMD Value	Equivalent Computer Interface Cmd
Timed reporting on	3001	SL1
Exception reporting on	3002	SL2
Timed reporting off	3003	SL3
Exception reporting off	3004	SL4
Computer interface off	3005	-
Initialize computer interface	3006	-
Generate report	3007	RD
Set days	31DD	
Set hours	32HH	STDDHHMM
Set minutes	33MM	
Set logging interval	34NN	SLINN

The computer interface must be initialized before it can be used. Initialization occurs whenever the power is turned on, CMD 3006 is entered from the keyboard, the watchdog circuit forces a reset, or a break signal at least 220 milliseconds long is received.

3.13 Summary of DIGITEL Commands

Command Functions		
2000	Change password	
	Old password, ENTER	
	New password, ENTER	
3001	Timed reporting on	
3002	Exception reporting on	
3003	Timed reporting off	
3004	Exception reporting off	
3005	Computer interface off	
3006	Initialize computer interface	
3007	Print report	
31DD	Set days (DD = 00-99)	
32HH	Set hours (HH = 00-23)	
33MM	Set minutes (MM = 00-59)	
34N	Set logging interval (min.3 (NN = 01-99)	

**Keyboard
Functions**

Pump on	HV ENABLE on POWER on OPER
Pump off	STBY
Voltage display	VOLTS
Current display	CURR
Pressure display	PRESS
Bakeout timer display	ENTER
Bakeout on	BAKE BAKE
Bakeout off	BAKE ENTER x 5
Examine or change setpoint	SP1 or SP2 Mantissa, exponent, ENTER On value Mantissa, exponent, ENTER Off value XXX0 (X = 0,1) Pressure (0), Current (1) Password required (1) HV interlock: On (0), Off (1) Not used. Set to (0). ENTER
Examine or change bakeout	BAKE ENTER Mantissa, exponent, ENTER On value Mantissa, exponent, ENTER Off value XXXX (X = 0,1) Pressure (0), Current (1) Password required (1) Pressure (0), Current (1) Password required (1) HV interlock: On (0), Off (1) Bakeout time-Continuous (0) Timing controlled by Heater (1) ENTER #Hours, ENTER Password, ENTER, (optional)

Computer Interface Commands	M1	Standby
	M2	Operate
	M3	Display voltage (on LEDs)
	M4	Display current
	M5	Display pressure
	M6	Bakeout enable
	M7	Bakeout disable
	M8	Keyboard on
	M9	Keyboard off
	SL1	Timed reporting on
	SL2	Exception reporting on
	SL3	Timed reporting off
	SL4	Exception reporting off
	SLINN	Logging interval (NN = 01-99)
	STDDHHMM	Set date and time
	RD	Print a report
	RC	Print AUTORUN parameters
RSX	Read setpoint parameters (X = 1-3)	
SNPXXYY	Set setpoint parameter N = Setpoint, P =Parameter #, XX or XXYY = Parameter value	
Errors From display	1	Invalid function
	2	Option not installed
	4	Logic error
	5	Cycle limit shutdown
	6	Invalid key
	8, 9	Hardware error
Errors From Computer Interface	11	Illegal password
	13	Keyboard disabled
	20	Input buffer overflow
	30	Invalid command
	31	Illegal character
	32	Illegal parameter value
	33	Option not installed

4 Service

Overview

This section on the DIGITEL™ 1500 provides the information on maintenance, calibration and troubleshooting.

DANGER!

Before servicing the DIGITEL, read the following:

- All repairs to the DIGITEL must be done at the factory.
- Service should always be performed by qualified personnel.
- Voltages up to 8000V are present. An interlock is provided to shut off power when the cover is removed. Do not defeat this interlock.
- Do not disconnect the high voltage cable with power on. After turning power off, allow at least one minute before disconnecting electrical equipment.
- Do not operate the control without a proper electrical ground or near water. The control may be damaged and its safety reduced, if it is operated outside of its specifications.

CAUTION!

Circuit boards may be destroyed by a small static discharge. To avoid damaging the boards, use the following precautions:

- Handle boards at approved ESD workstation.
 - Do not touch any electrical contacts.
 - Do not rub boards against any insulator that may build up a static charge.
 - When shipping boards, use approved ESD containers and packaging.
-

4.1 Maintenance

Table 4-1 provides the routine maintenance schedule for the DIGITEL. Figure 4-1 shows the location of these components.

Table 4-1. Routine Maintenance Schedule

Maintenance	How often?
Change the air filter	every six months
Clean the chassis interior	every six months
Replace lamps	as necessary
Replace fuses	as necessary

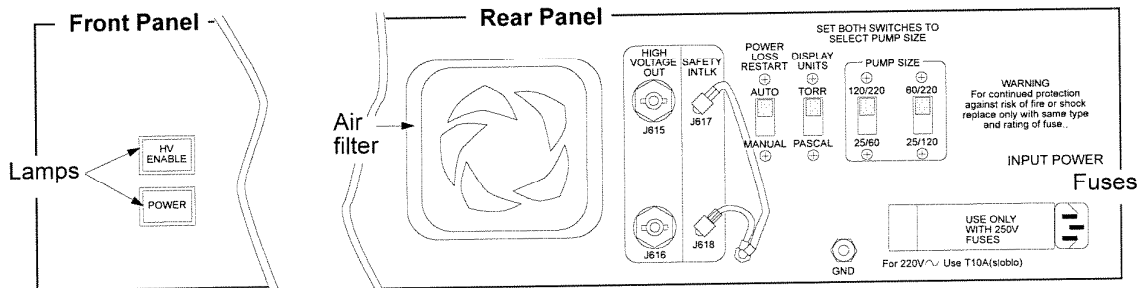

Figure 4-1. Location of Maintenance Components

Top cover removal

To gain access to the unit interior, remove the six screws securing the top cover to the chassis. These are located on both sides of the unit.

Cleaning the chassis

1. Turn power off to the unit. Wait two minutes and remove the top cover.
2. Clean the interior of the chassis with clean, oil-free, compressed air at 50 psi maximum.
3. Clean all high voltage wiring and connections, since they are susceptible to arcing.
4. Inspect the HV insulation for cracks. If you find any, contact your service representative.
5. When replacing the cover, make sure that the ventilation holes are near the front of the cover.

Cleaning the air filter

The air filter is located on the rear panel.

1. To remove the filter, gently compress it and pull the filter out of the metal frame.
2. Clean the filter with warm water to remove dust and dirt that may restrict air flow.
3. After the air filter is completely dry, carefully compress and insert it into the metal frame.

Replacing lamps

The lamps are housed under the lenses of the **HV ENABLE** and **POWER** switches.

1. Ensure that the switches are in the off position (not flush with the bezel).
2. Insert a small screwdriver into the notch at the top of the lens.
3. Gently pull the lens forward until it is free of the housing.
4. Locate the lamp puller inside the housing, and pull it forward to free the lamp.
5. Replace the lamp with a type CM85 (28V, T 1-3/4 wedge base) lamp or equivalent.
6. Carefully push the lamp back into the socket and snap the lens into place.

Replacing fuses

Spare fuses may be stored in two rectangular boxes at the front of the voltage selection block. Use a screwdriver to push out the plastic fuse holder.

Table 4-1. Fuse Replacement Parts

Fuse Type	Part Number
4A, 250V, slo blow	618926
10A, 250V, slo blow	627459

4.2 Calibration

When to calibrate?

All units are calibrated before shipment from the factory. Periodic calibration is generally not required.

Before you begin

Use a DVM as an ammeter and place it in series with a variable power supply.

Adjust the voltage of the variable power supply until the desired current is obtained.

Calibration procedure

Perform the following calibration procedure.

1. Push the front panel **POWER** switch to off (not flush with the bezel).
2. Wait for two minutes and remove the top cover.
3. Disconnect J405 on the Power Supply board (Figure 4-2).
4. Push the front panel **HV ENABLE** switch off (not flush).
5. Plug in the power cable.
6. Pull the safety interlock switch up (Figure 4-2) to disable it.

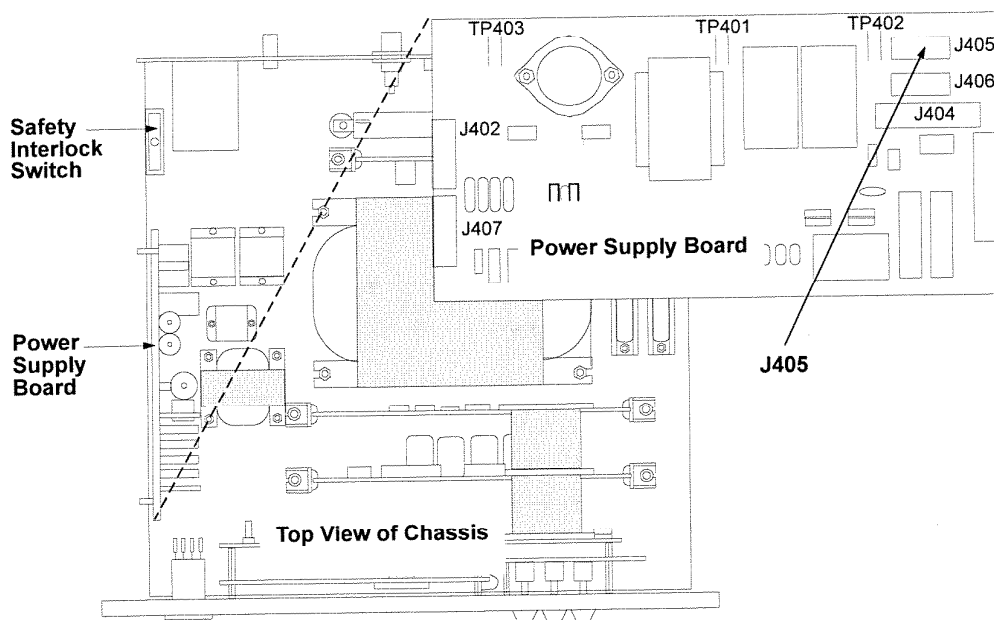

Figure 4-2. J405 and Safety Interlock

7. Push the **POWER** switch to on (flush with the bezel).
8. Connect a voltmeter between TP305 and TP303 (ground) on the CPU board to check the voltage reference. If necessary, adjust R317 to obtain a DVM reading of -3.06V (Figure 4-3).
Disconnect the DVM.
9. Press the **CURR 5** key to enter the current display mode.
10. Check the zero adjustment. If necessary, adjust R311 so that the front panel display reads 0.0×10^{-5} .

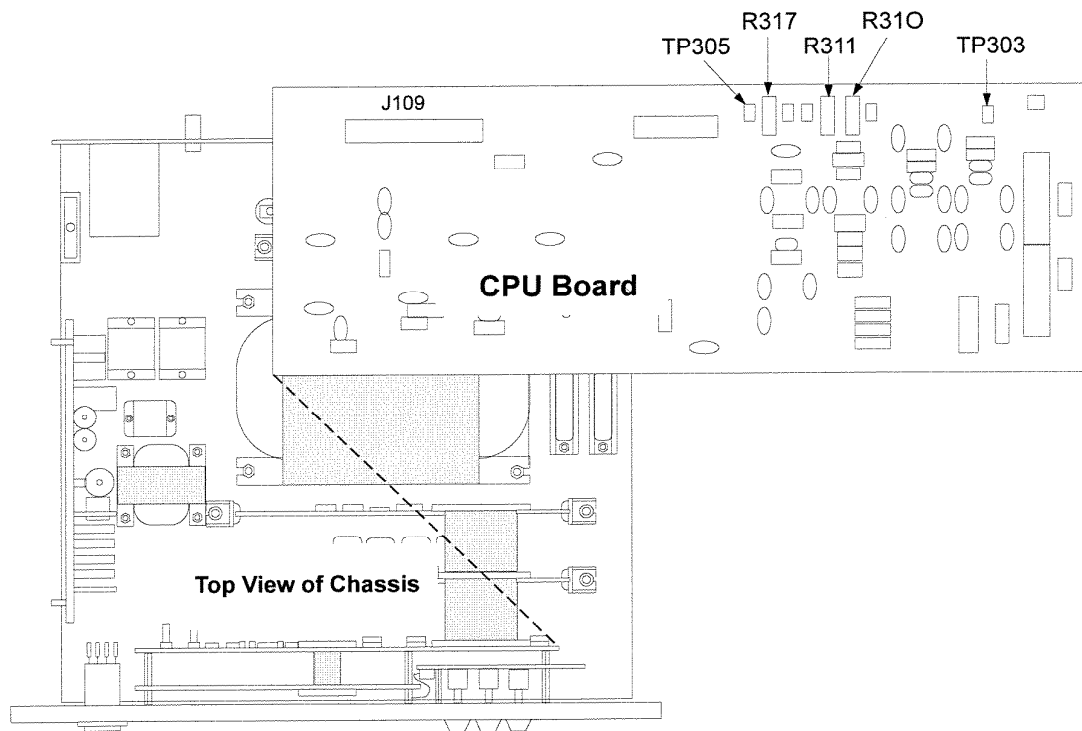

Figure 4-3. CPU Board Calibration Components

11. Disconnect the power cable from the rear of the unit.

12. On the HV Board, short E501 and E502 together with a jumper wire (Figure 4-4).

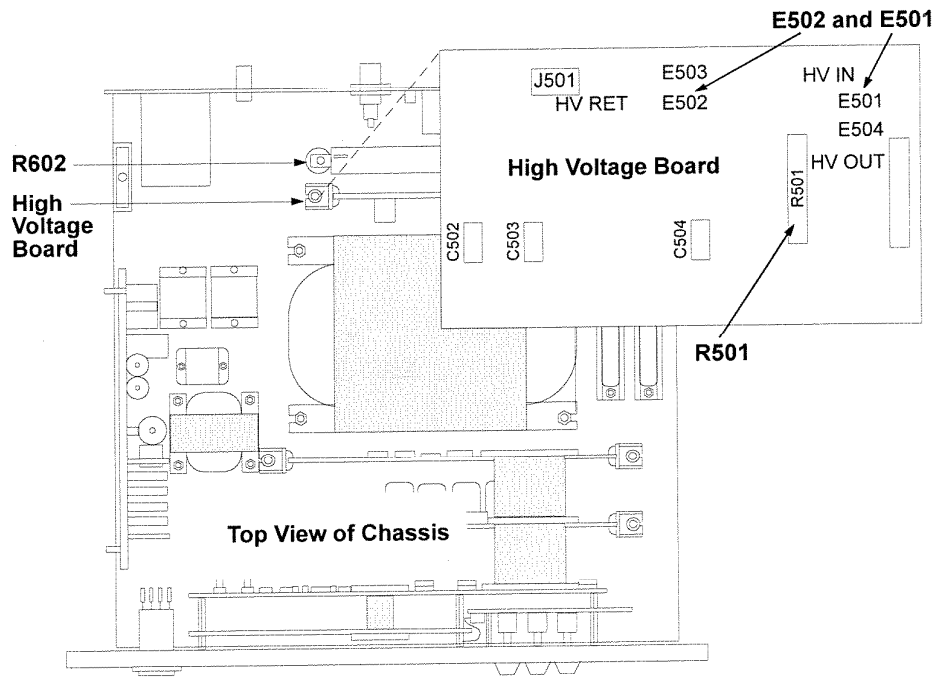

Figure 4-4. Calibration Components on the HV Board

13. Short R602 (500Ω, 100W mounted to the chassis) with a jumper wire (Figure 4-4).
14. Connect a variable current source between E502 and the chassis.
15. Connect a power cord.
16. To check the gain of the amplifier, adjust the variable current source for an output of 30 mA. Press the **CURR 5** key. Adjust R310 on the CPU board (Figure 4-3) so the front panel display reads 3.0×10^{-2} .
17. Check the following gains:

Current Source	Front Panel Display
300 mA	$3.0 \times 10^{-1} \pm 1 \text{ digit}, \pm 5\%$
3 mA	$3.0 \times 10^{-3} \pm 1 \text{ digit}, \pm 5\%$
300 μA	$3.0 \times 10^{-4} \pm 1 \text{ digit}, \pm 5\%$

19. Disconnect the power cord from the chassis.
20. Remove the jumper at E501 and E502, and short out R501 on the HV board (Figure 4-4).
21. Reconnect the power cord.
22. Check calibration of the voltage display mode. Inject a current of 259 μ A and check for a display of 5000 \pm 100V, \pm 5%.
23. Disconnect the power cord from the chassis
24. Remove jumpers at R602 and R501. Reconnect J405.
25. Replace the top cover.

4.3 Troubleshooting

Setpoint Option	Symptom	Possible Cause
	Cannot change password. Correct password unknown.	Replace setpoint board EEPROM
	Setpoint relays do not transfer	<ol style="list-style-type: none"> 1. Setpoints not programmed. 2. Current or pressure too high. 3. Check cable from setpoint board to rear panel. 4. Setpoint board.
	Error message received when SP1 or SP2 is pressed on keyboard.	<ol style="list-style-type: none"> 1. Check ribbon cable from CPU board to display board. 2. Setpoint board.
	Setpoints are lost when unit is turned off and on again.	<ol style="list-style-type: none"> 1. EEPROM defective. 2. EEPROM disable circuitry defective. Check U707 and Q701.
Computer Interface Option	Symptom	Possible Cause
	Computer Interface not operating.	<ol style="list-style-type: none"> 1. Computer interface board. 2. Check baud rate on DIGITEL and host device. 3. Check cable from CPU board to computer interface board. 4. Interface not properly made to host device.

**Main
Unit**

Symptom	Possible Cause
Display does not light when the DIGITEL is turned on. Unit is completely dead.	<ol style="list-style-type: none">1. Power not connected to unit.2. Check fuse on back panel and fuses on power supply board.3. Cover loose or removed.4. Check Voltage Select switch setting.
Display lit. Unit does not respond to keyboard.	<ol style="list-style-type: none">1. Keyboard not plugged in properly.2. Shorted key
Display not lit. Power light works. HV light flashes and then lights continuously.	<ol style="list-style-type: none">1. Check ribbon cable from CPU board to display board.2. Display board.3. CPU board.
Unit goes into cool-down mode early.	<ol style="list-style-type: none">1. Check pump select switch setting.2. Shorted HV cable.3. Defective ion pump.4. Contaminated ion pump.5. Excessive gas load.
Display not lit. Power light lit. Unit is inoperable.	<ol style="list-style-type: none">1. Defective 5V supply. Check TP403 (Figure 4-5).2. Display board.3. CPU board.
Displayed current and voltage readings are incorrect.	<ol style="list-style-type: none">1. Defective +15V supply. Check TP401 (Figure 4-5).2. Defective -15V supply. Check TP401 (Figure 4-5).3. Check -5.1V reference adjustment. See calibration procedure.
Displayed pressure reading is incorrect.	<ol style="list-style-type: none">1. Check pump select switch.2. Check torr/pascal setting.
No high voltage output.	<ol style="list-style-type: none">1. HV enable switch is in Off position.2. Unit in standby mode.3. Primary of HV transformer disconnected from power supply board.4. Power supply board.5. HV board.

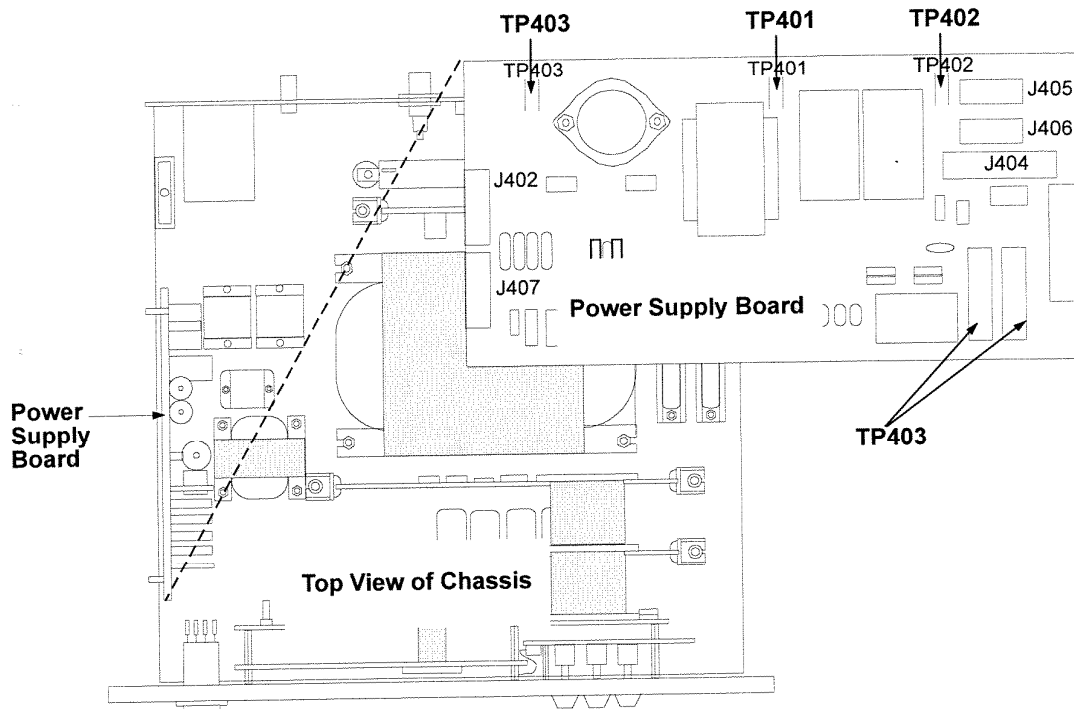

Figure 4-5. Location of Troubleshooting Components

4.4 CMD Service Functions

In current mode, the CPU Board selects IHIGH or ILOW and gains of 1, 10, or 100 to provide an appropriate level signal for the A/D converter. This analog multiplexing may be frozen and certain analog switches selected by using keyboard commands listed below. These commands should only be used during service by a qualified electronic technician.

Command	Source	Gain
0817	ILOW	1
0809	ILOW	10
0801	ILOW	100
0818	IHIGH	1
0810	IHIGH	10
0802	IHIGH	100
0880	HV	1
0800	Multiplexed (normal) Operation	

4.5 Optional Accessory Equipment

Model Number	Description	Ship Weight	
		Lbs	Kg
100-0438	Bakeable HV cable for ion pump control units, 15' long.	2	0.9
100-1515	Bakeable HV Cable, 20' long.	2	0.9
100-1516	Bakeable HV Cable, 30' long.	2	1.4
100-1518	Bakeable HV Cable, 50' long.	2	1.4
222-0401	Computer interface option RS-232	1	0.5
222-0402	Setpoint option	1	0.5
222-0403	Bakeout/Setpoint option	1	0.5

5 Theory of Operation

The theory of operation of the DIGITEL 1500™ described in this section is used with the following schematics, which can be found in Section 6.

- Chassis Schematic 1004843
- High Voltage Board Schematic 1004776
- Low Voltage Power Supply Schematic 625703
- CPU Board Schematic 615741
- Display Board Schematic 1003223
- Keyboard Schematic 1003219
- Setpoint Board Schematic 1003203
- Computer Interface Schematic 1003227

5.1 Chassis (Schematic 1004843)

The chassis consists of the primary wiring, board interconnect, and high voltage power supply. Safety interlock S601 removes power when the top cover is removed. S602 controls power to low-voltage transformer T401. Since relay K401, which controls power to T601, cannot be energized when T401 is off, S602 indirectly controls DIGITEL power.

T601 is a current-limiting transformer. Its short circuit current is 750 mA at nominal line. The magnetic characteristics of T601, when combined with the electrical characteristics of the bridge rectifier and capacitor, yield a dc voltage vs. current curve that is suitable for ion pumps in the range of 120 L/s and larger. When current load is light, D601 and C601 behave as a voltage doubler. As current increases, the circuit acts like a full-wave bridge rectifier.

R508 serves as a bleed down resistor. E501 and E502 connect to HV IN and HV RETURN on the high voltage processing board. The HV output is at E504 and E503. R602 dissipates energy during ion pump arcing, protecting other power supply components. The DIGITEL is supplied with high voltage output connectors located at J615 and J616.

5.2 HV (High Voltage) Board (Schematic 1004776)

The HV board is the interface between high voltage output and the CPU board. To accommodate electronics, high voltage is stepped

down by resistors R501 and R502. The current drawn by this network is returned to HV RETURN so it bypasses the current sensing network. This requires that the voltage is sensed as the difference between the HV and ILOW outputs. R505, C504, and diodes D507 - 508 protects the CPU board in case of power failure. AC capacitor C504 reverses the polarity of the power supply without changing the metering circuits.

R504 is the current shunt for IHIGH output, while R503 provides a similar function for ILOW output. When high current is drawn, D501-502 conducts, limiting heat dissipated in R503. C502-503, D503-506, and R506-507 also provide protection to the CPU board components.

5.3 Low Voltage Power Supply (Schematic 625703)

The power supply board provides power to run the microprocessor analog circuits and to control high voltage primary power.

Input line voltage is fused by F401-402 to protect against power failure. The fan is wired across one primary of T401 to provide Vac operation. For fire protection, the secondary of T401 contains internal, temperature sensitive fuses. The output of T401 is rectified, filtered, and regulated to provide the +5V, $\pm 15V$ regulated, and +12V unregulated outputs.

A control signal from the CPU board turns Q402 on and off to enable the primary of the high voltage transformer. U401-402 and Q401 control the HV enable lamp on the front panel.

5.4 CPU Board (Schematic 615741)

The CPU board consists of a digital section (100 series components) and an analog section (300 series components). It is the main control point for all activities in the DIGITEL.

The main CPU clock is controlled by a 2.4576 MHz crystal. This signal is divided down to 614.4 kHz at U101 for the timing of the digital logic. U102 decodes the CPU address and control signals to enable memory and I/O devices as required. U103 contains the main DIGITEL software EPROM. The 128-byte RAM (U104) increases the CPU RAM to provide a total of 256 bytes. U105 and U107 are universal, parallel, I/O devices. U105 provides control of analog conditioning circuits on pins 2 through 9. Pins 10 through 13 read rear panel status switches. Pin 39 provides a watchdog output signal. If

this signal turns off, possibly due to a soft CPU error, timer U109 times out and resets the CPU. Pin 40 is the Real Time Clock (RTC) input. The CPU uses this signal for all timing, including display multiplexing.

U107 interfaces the CPU to the display board. J109 extends the CPU bus to the option boards, and may not be used in all installations.

Analog signals enter the board on J301. D301-306 provide protection to high impedance input stages. Since voltage is measured as the difference between HV and ILOW, U301-303 form an instrumentation amplifier that measures it. U303 output is buffered by U310 and output on the rear panel. Output current is buffered by U309.

Analog inputs (IHIGH, ILOW, and HV) are selected by the CPU using dialectically isolated analog switches. The selected signal is directed to variable gain amplifier U304. The CPU can select gains of 1, 10, or 100 by turning the appropriate analog switches on or off. U305 and U306 form an automatic polarity circuit. No matter what the input polarity, the output is positive with a gain of one.

This signal is then digitized by the 8-bit, successive approximation, A/D converter U308. D307 and U307 form an adjustable $-3.06V$ reference. The microprocessor continuously samples both current and voltage, alternately. Gain in the voltage mode is always one. In current mode, the CPU selects IHIGH or ILOW and gains of 1, 10, or 100 to provide an appropriate level signal for the A/D converter.

5.5 Display Board (Schematic 1003223)

The display board contains all LED drivers and the keyboard interface. All LEDs (except DS213-216) and the keyboard are multiplexed. These are driven from 4/6 U205 because of their high current requirement. The multiplexed array consists of DS201-212 and DS701-703 on the keyboard. The scanning sequence places the digit number on U203 input, which is decoded to an individual digit select line. This signal then drives U204 and 1/6 U205, which provides buffering and current sink for the selected digit. The segment information is then placed on the inputs to U201-202. These devices provide the drive current for the selected LED. After 3.3 ms, the drive is shut off, the next digit is selected, and the process is repeated. The entire array is scanned in 23 ms. Because of the slow response time of the human eye, it appears that all LEDs are lit simultaneously.

5.6 Keyboard (Schematic 1003219)

The keyboard connects to the display board and provides three status LEDs and 11 key matrix. The LEDs are driven by electronics on the display board. The keyboard and LEDs are multiplexed by the same digit select signal. The CPU can determine which key is pressed by the combination of input and output signals.

5.7 Setpoint Board (Schematic 1003203)

The optional setpoint board provides three setpoint relay outputs — remote, standby, and operate inputs. There is a fourth relay output if this board is used in the bakeout option.

Connection to the microprocessor bus is made through J709. The firmware that controls the setpoint and bakeout logic is stored in 4K EPROM U701. EEPROM U702 stores the setpoint and bakeout values. Since this device retains data without power, these values are permanently stored. U707 and associated circuitry disable U702 during power up/power down to prevent data from being written to U702 during transient power conditions. U703 is a universal parallel I/O device. Its PB0-3 outputs control the four output relays through relay driver U704. Remote standby and operate inputs are optically isolated by U705-706 and read on PB6-7, which are programmed as inputs. PB0-1 controls the non-volatile store and write functions on U702.

5.8 Computer Interface (Schematic 1003227)

The computer interface option provides an RS-232/422 serial interface. U801 is a 4K-byte EPROM containing firmware to drive the interface. U802 is the serial to data bus converter. It communicates with an external device using TTL to RS-232 interface IC (U803) and an RS-232 to TTL IC (U804). U805 divides the 614.4 kHz master clock for the available data transmission rates. The rate is selected by S801-807. U806 and Q801 form the break detection circuitry. When a break (a mark signal) is transmitted by the remote device, Q11 on U806 goes high after 213 ms, turning Q801 on and forcing a master CPU reset. VR801-802 convert the $\pm 15V$ supplies to $\pm 12V$ for use by U803-804.

6 Drawings and Parts Lists

This section provides the assembly drawings and schematics for the DIGITEL™ 1500. The assembly drawings (followed by its parts list) and schematics are presented in the following order:

<i>Assembly drawings and parts list</i>	• 2221500	Control DIGITEL Top Level Assembly
	• 615740	CPU PCB Assembly
	• 625702	Power Supply PCB Assembly
	• 1004747	H. V. Board PCB Assembly
	• 1003220	Display PCB Assembly
	• 630221	Keyboard PCB Assembly
	• 1003200	Setpoint PCB Assembly
	• 623011	RS232 Computer Interface PCB Assembly
<i>Schematics</i>	• 1004803	Chassis Schematic
	• 615741	CPU Schematic
	• 625703	Power Supply Schematic
	• 1004776	H. V. Board Schematic
	• 1003223	Display Board Schematic
	• 1003219	Keyboard Schematic
	• 1003203	Setpoint Schematic
	• 623012	RS232 Computer Interface Schematic

Index

—A—	
Air filter maintenance	4-3
Analog outputs	3-10
ASCII conversion.....	3-20
Assembly part numbers.....	6-1
Autorun	3-7
—B—	
Bakeout	2-9,3-18
Bargraph, Rate-of-Rise	3-2,6
—C—	
Calibration.....	4-4
CMD functions.....	3-11,4-9
Commands, summary of.....	3-25
Computer interface option	
board installation	2-8
commands.....	3-24
electrical connections.....	2-12
error codes	3-23
operation	3-19
Controls, front panel	3-2
Conversion constants, pressure	3-5
Cool-down.....	3-7
Current mode	3-4
—D—	
Description.....	1-1
Display	3-2,4
—E—	
Error Messages.....	3-8
Evacuating the pump.....	3-3
—F—	
Functions,CMD.....	3-11,4-9
Front panel controls	3-2
Fuse replacement	4-3
—H—	
High voltage enable switch.....	3-2
—I—	
Ion pump	
current/voltage measuring	3-10
evacuating.....	3-3
size selection.....	3-1
starting	3-4
Installation.....	2-1
—K—	
Keypad	3-2,10
—L—	
Lamp replacement.....	4-3
Leak detection.....	3-6
—M—	
Maintenance.....	4-2
Messages, user	3-8
Modes of operation	3-4
—O—	
Operation	
analog outputs.....	3-10
autorun	3-7
bakeout.....	3-18
CMD functions	3-11
display.....	3-4
ion pump	3-3
keypad.....	3-10
modes.....	3-4
password protection.....	3-16
Rate-of-Rise bargraph.....	3-6
user messages	3-8
Optional equipment.....	4-10

Options	
bakeout.....	2-9,3-18
computer interface	2-7,3-19,5-4
electrical connections	2-10
setpoint	2-5,3-11,5-4

—P—

Password protection	3-16
Pressure conversion constants.....	3-5
Pressure display selection	3-1
Pressure mode	3-4
Procedures	
bakeout.....	2-9,3-18
calibration	4-4
installation	2-2
leak detection.....	3-6
option board installation	2-4
password protection.....	3-16
programming setpoint.....	3-13
Programming setpoint parameters	3-13
Pump	
current/voltage measuring	3-10
evacuating.....	3-3
size selection.....	3-1
starting	3-4

—R—

Rate-of-Rise bargraph	3-2,6
Rear panel	3-1

—S—

Schematics	6-1
Service.....	4-1
Setpoint option.....	3-11
board installation	2-5
electrical connections.....	2-10
setting parameters	3-13
Specifications.....	1-2
Starting the pump.....	3-4
Status messages.....	3-9

—T—

Theory of Operation.....	5-1
Chassis	5-1
Computer Interface board.....	5-4
CPU board	5-2
Display board.....	5-3
High Voltage board	5-2
Keyboard	5-4
Low Voltage power supply.....	5-2
Setpoint board.....	5-4
Top cover removal	4-2
Troubleshooting	4-7

—U—

User messages.....	3-8
--------------------	-----

—V—

Voltage mode	3-4
--------------------	-----

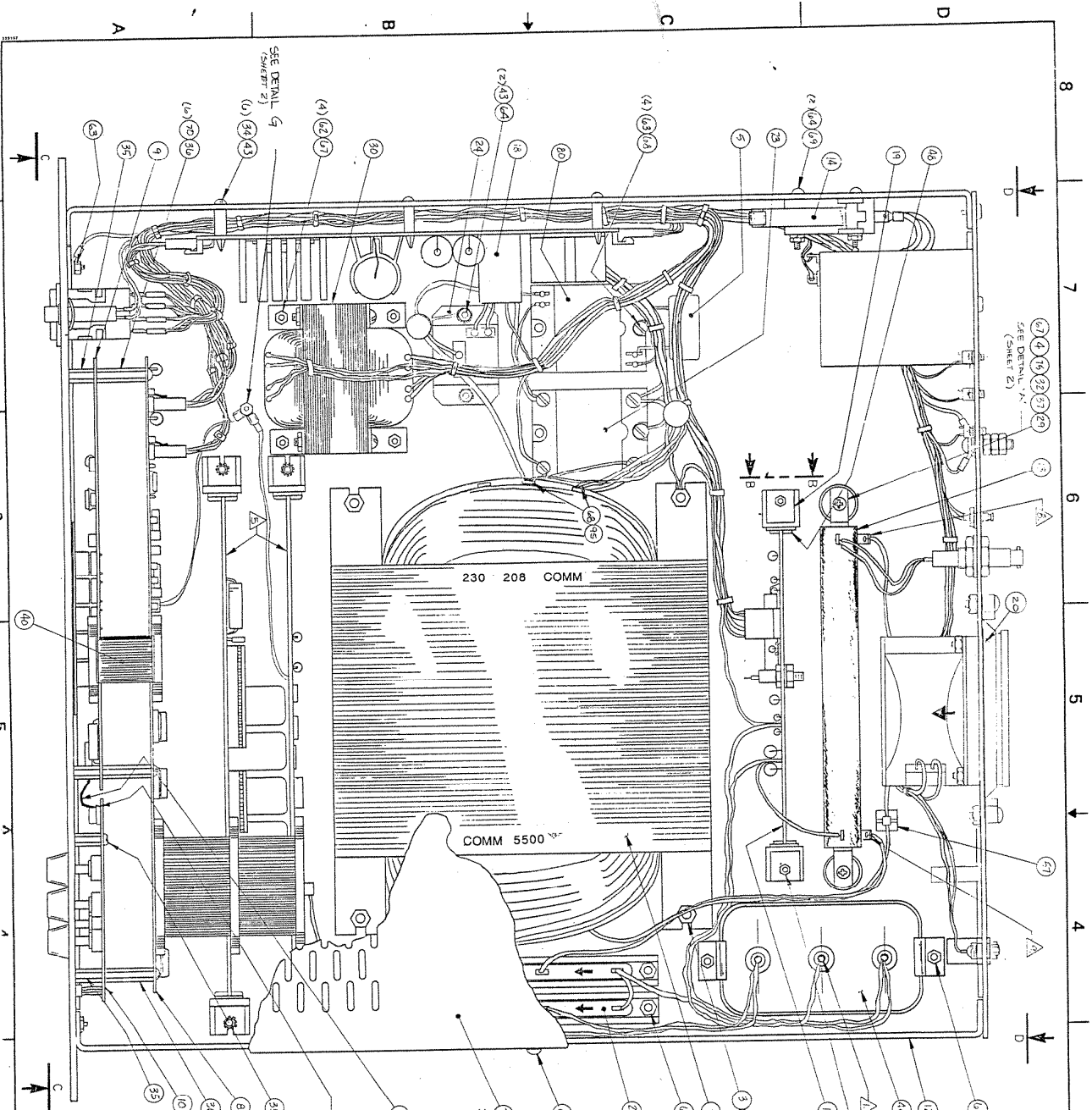

REV.	DESCRIPTION	DATE	APPROVED
1	ISSUED FOR FABRICATION BY CHARTER	7/21/50	J. W. BROWN
2	SEE COMMENTS	7/21/50	J. W. BROWN
3	SEE CO 112045 4/8/50	5/14/50	J. W. BROWN
4	SEE CO 112045 4/8/50	5/14/50	J. W. BROWN
5	SEE CO 112045 4/8/50	5/14/50	J. W. BROWN
6	SEE CO 112045 4/8/50	5/14/50	J. W. BROWN
7	SEE CO 112045 4/8/50	5/14/50	J. W. BROWN
8	SEE CO 112045 4/8/50	5/14/50	J. W. BROWN
9	SEE CO 112045 4/8/50	5/14/50	J. W. BROWN
10	SEE CO 112045 4/8/50	5/14/50	J. W. BROWN
11	SEE CO 112045 4/8/50	5/14/50	J. W. BROWN
12	SEE CO 112045 4/8/50	5/14/50	J. W. BROWN
13	SEE CO 112045 4/8/50	5/14/50	J. W. BROWN
14	SEE CO 112045 4/8/50	5/14/50	J. W. BROWN
15	SEE CO 112045 4/8/50	5/14/50	J. W. BROWN
16	SEE CO 112045 4/8/50	5/14/50	J. W. BROWN
17	SEE CO 112045 4/8/50	5/14/50	J. W. BROWN
18	SEE CO 112045 4/8/50	5/14/50	J. W. BROWN
19	SEE CO 112045 4/8/50	5/14/50	J. W. BROWN
20	SEE CO 112045 4/8/50	5/14/50	J. W. BROWN
21	SEE CO 112045 4/8/50	5/14/50	J. W. BROWN
22	SEE CO 112045 4/8/50	5/14/50	J. W. BROWN
23	SEE CO 112045 4/8/50	5/14/50	J. W. BROWN
24	SEE CO 112045 4/8/50	5/14/50	J. W. BROWN
25	SEE CO 112045 4/8/50	5/14/50	J. W. BROWN
26	SEE CO 112045 4/8/50	5/14/50	J. W. BROWN
27	SEE CO 112045 4/8/50	5/14/50	J. W. BROWN
28	SEE CO 112045 4/8/50	5/14/50	J. W. BROWN
29	SEE CO 112045 4/8/50	5/14/50	J. W. BROWN
30	SEE CO 112045 4/8/50	5/14/50	J. W. BROWN
31	SEE CO 112045 4/8/50	5/14/50	J. W. BROWN
32	SEE CO 112045 4/8/50	5/14/50	J. W. BROWN
33	SEE CO 112045 4/8/50	5/14/50	J. W. BROWN
34	SEE CO 112045 4/8/50	5/14/50	J. W. BROWN
35	SEE CO 112045 4/8/50	5/14/50	J. W. BROWN
36	SEE CO 112045 4/8/50	5/14/50	J. W. BROWN
37	SEE CO 112045 4/8/50	5/14/50	J. W. BROWN
38	SEE CO 112045 4/8/50	5/14/50	J. W. BROWN
39	SEE CO 112045 4/8/50	5/14/50	J. W. BROWN
40	SEE CO 112045 4/8/50	5/14/50	J. W. BROWN
41	SEE CO 112045 4/8/50	5/14/50	J. W. BROWN
42	SEE CO 112045 4/8/50	5/14/50	J. W. BROWN
43	SEE CO 112045 4/8/50	5/14/50	J. W. BROWN
44	SEE CO 112045 4/8/50	5/14/50	J. W. BROWN
45	SEE CO 112045 4/8/50	5/14/50	J. W. BROWN
46	SEE CO 112045 4/8/50	5/14/50	J. W. BROWN
47	SEE CO 112045 4/8/50	5/14/50	J. W. BROWN
48	SEE CO 112045 4/8/50	5/14/50	J. W. BROWN
49	SEE CO 112045 4/8/50	5/14/50	J. W. BROWN
50	SEE CO 112045 4/8/50	5/14/50	J. W. BROWN
51	SEE CO 112045 4/8/50	5/14/50	J. W. BROWN
52	SEE CO 112045 4/8/50	5/14/50	J. W. BROWN
53	SEE CO 112045 4/8/50	5/14/50	J. W. BROWN
54	SEE CO 112045 4/8/50	5/14/50	J. W. BROWN
55	SEE CO 112045 4/8/50	5/14/50	J. W. BROWN
56	SEE CO 112045 4/8/50	5/14/50	J. W. BROWN
57	SEE CO 112045 4/8/50	5/14/50	J. W. BROWN
58	SEE CO 112045 4/8/50	5/14/50	J. W. BROWN
59	SEE CO 112045 4/8/50	5/14/50	J. W. BROWN
60	SEE CO 112045 4/8/50	5/14/50	J. W. BROWN
61	SEE CO 112045 4/8/50	5/14/50	J. W. BROWN
62	SEE CO 112045 4/8/50	5/14/50	J. W. BROWN
63	SEE CO 112045 4/8/50	5/14/50	J. W. BROWN
64	SEE CO 112045 4/8/50	5/14/50	J. W. BROWN
65	SEE CO 112045 4/8/50	5/14/50	J. W. BROWN
66	SEE CO 112045 4/8/50	5/14/50	J. W. BROWN
67	SEE CO 112045 4/8/50	5/14/50	J. W. BROWN
68	SEE CO 112045 4/8/50	5/14/50	J. W. BROWN
69	SEE CO 112045 4/8/50	5/14/50	J. W. BROWN
70	SEE CO 112045 4/8/50	5/14/50	J. W. BROWN
71	SEE CO 112045 4/8/50	5/14/50	J. W. BROWN
72	SEE CO 112045 4/8/50	5/14/50	J. W. BROWN
73	SEE CO 112045 4/8/50	5/14/50	J. W. BROWN
74	SEE CO 112045 4/8/50	5/14/50	J. W. BROWN
75	SEE CO 112045 4/8/50	5/14/50	J. W. BROWN
76	SEE CO 112045 4/8/50	5/14/50	J. W. BROWN
77	SEE CO 112045 4/8/50	5/14/50	J. W. BROWN
78	SEE CO 112045 4/8/50	5/14/50	J. W. BROWN
79	SEE CO 112045 4/8/50	5/14/50	J. W. BROWN
80	SEE CO 112045 4/8/50	5/14/50	J. W. BROWN
81	SEE CO 112045 4/8/50	5/14/50	J. W. BROWN
82	SEE CO 112045 4/8/50	5/14/50	J. W. BROWN
83	SEE CO 112045 4/8/50	5/14/50	J. W. BROWN
84	SEE CO 112045 4/8/50	5/14/50	J. W. BROWN
85	SEE CO 112045 4/8/50	5/14/50	J. W. BROWN
86	SEE CO 112045 4/8/50	5/14/50	J. W. BROWN
87	SEE CO 112045 4/8/50	5/14/50	J. W. BROWN
88	SEE CO 112045 4/8/50	5/14/50	J. W. BROWN
89	SEE CO 112045 4/8/50	5/14/50	J. W. BROWN
90	SEE CO 112045 4/8/50	5/14/50	J. W. BROWN
91	SEE CO 112045 4/8/50	5/14/50	J. W. BROWN
92	SEE CO 112045 4/8/50	5/14/50	J. W. BROWN
93	SEE CO 112045 4/8/50	5/14/50	J. W. BROWN
94	SEE CO 112045 4/8/50	5/14/50	J. W. BROWN
95	SEE CO 112045 4/8/50	5/14/50	J. W. BROWN
96	SEE CO 112045 4/8/50	5/14/50	J. W. BROWN
97	SEE CO 112045 4/8/50	5/14/50	J. W. BROWN
98	SEE CO 112045 4/8/50	5/14/50	J. W. BROWN
99	SEE CO 112045 4/8/50	5/14/50	J. W. BROWN
100	SEE CO 112045 4/8/50	5/14/50	J. W. BROWN

THIS DRAWING, INCLUDING ALL ATTACHED SHEETS, IS THE PROPERTY OF THE UNITED STATES GOVERNMENT. IT IS LOANED TO YOU AND IS NOT TO BE DISTRIBUTED OUTSIDE YOUR ORGANIZATION. IT IS TO BE RETURNED TO THE OFFICE OF ORIGINATOR UPON REQUEST. THIS DRAWING IS NOT TO BE REPRODUCED OR TRANSMITTED IN ANY FORM OR BY ANY MEANS, ELECTRONIC OR MECHANICAL, INCLUDING PHOTOCOPYING, RECORDING, OR BY ANY INFORMATION STORAGE AND RETRIEVAL SYSTEM, WITHOUT PERMISSION IN WRITING FROM THE UNITED STATES GOVERNMENT.

UNLESS OTHERWISE SPECIFIED:
 DIMENSIONS ARE IN INCHES
 DIMENSIONS IN PARENTHESES ARE IN MILLIMETERS
 DIMENSIONS IN BRACKETS ARE IN METERS
 DIMENSIONS IN SQUARE BRACKETS ARE IN CENTIMETERS
 DIMENSIONS IN DIAMETERS ARE INDICATED BY Ø
 DIMENSIONS IN RADIUSES ARE INDICATED BY R
 DIMENSIONS IN ANGLES ARE INDICATED BY °

SEE DETAIL E (SHEET 2)
 SEE DETAIL G (SHEET 2)
 SEE DETAIL H (SHEET 2)

NOTE 5:
 1. APPLY HOT GLUE TO 3 TERMINALS OF TRANSFORMER (ITEM 44) AFTER SOLDERING.
 2. POWER CORD AND GND CABLE MUST NOT SHARE THESE FRAMES ARE SUPPLIED AND STOCKED WITH THE FINISHED UNIT.
 3. HOT VOLTAGE LABEL TO BE AFFIXED TO THE REAR OF COVER ON CENTERLINE OF THE UNIT.
 4. PRING LABEL TO BE AFFIXED TO REAR PANEL AFTER MOUNTING OF MODEL NO. AND PART NO. ON LABEL.
 5. SET POINT OPTION AND COMPUTER INT. OPTION SHOULD BE RECEIVED ONLY. THESE OPTIONS ARE INSTALLED BEFORE SHIPMENT IF ORDERED WITH MAIN UNIT.
 6. HOT OPS ARE INSTALLED IN 4U, 10U, 10U REMOTE WHICH OPNS ARE INSTALLED IN 4U, 10U REMOTE.
 7. REMOVE FUSE FROM CORD ITEM 25) & INSTALL CONT. FUSE (1A) IN ITS PLACE. ATTACH LABEL (ITEM 102) TO FEMALE END OF CORD. SEE DETAIL H.
 8. ROTATE RIGS SO SOLDER TABS ARE AT 45° FROM MASSIVE BEAD BRACKETS ON BOTTOM RESISTOR ONLY (RIGS).

NOTE 6:
 CRIMP BOTH INNER CONDUCTOR & BRAIDED SHIELD OF COAXIAL CABLE, ITEM 78, INTO LUGS, ITEM 85.

NOTE 7:
 CRIMP BOTH INNER CONDUCTOR & BRAIDED SHIELD OF COAXIAL CABLE, ITEM 78, INTO LUGS, ITEM 85.

SEE DETAIL F L.
 SEE DETAIL G L.
 SEE DETAIL H L.
 SEE DETAIL I L.
 SEE DETAIL J L.
 SEE DETAIL K L.
 SEE DETAIL L L.
 SEE DETAIL M L.
 SEE DETAIL N L.
 SEE DETAIL O L.
 SEE DETAIL P L.
 SEE DETAIL Q L.
 SEE DETAIL R L.
 SEE DETAIL S L.
 SEE DETAIL T L.
 SEE DETAIL U L.
 SEE DETAIL V L.
 SEE DETAIL W L.
 SEE DETAIL X L.
 SEE DETAIL Y L.
 SEE DETAIL Z L.

DRAWING NO. 222-1500
 REVISIONS
 1

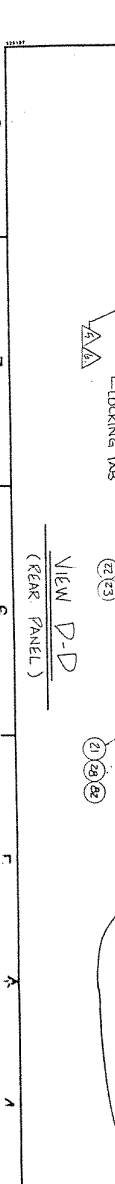
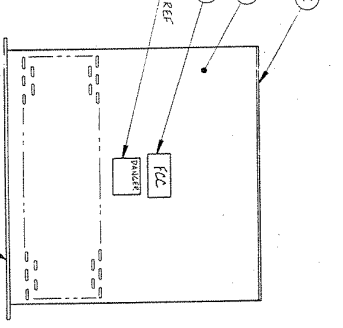
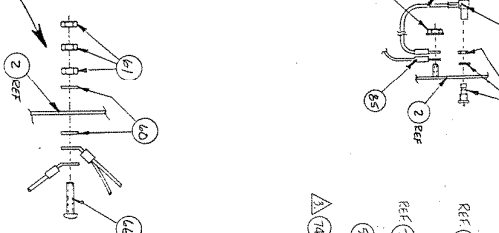
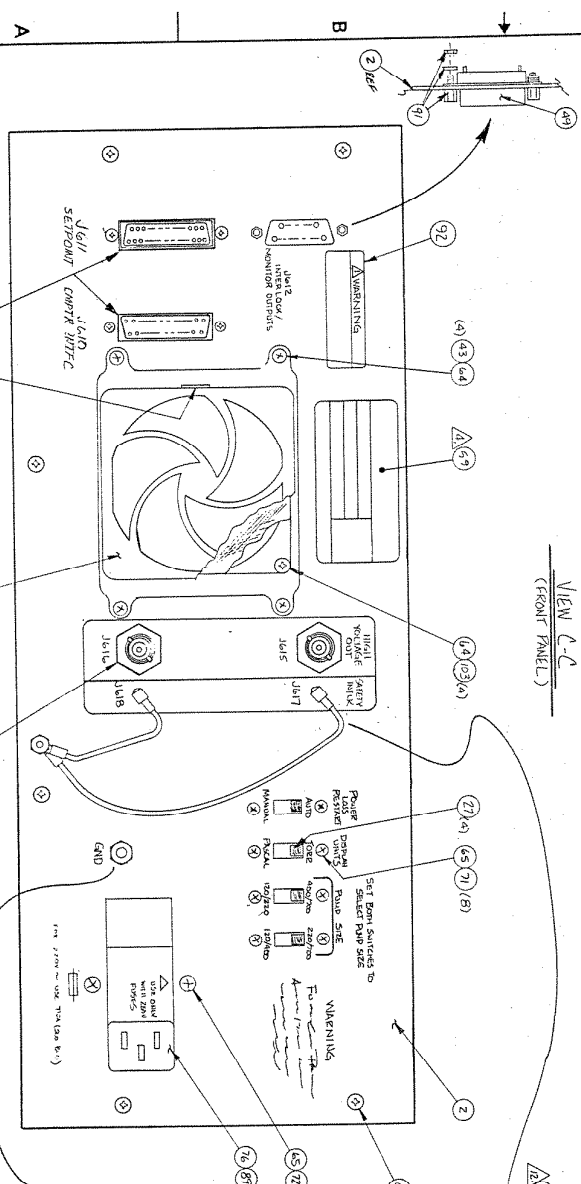
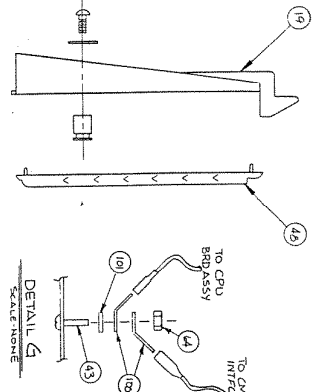
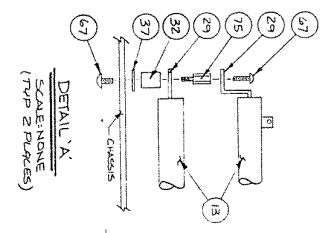
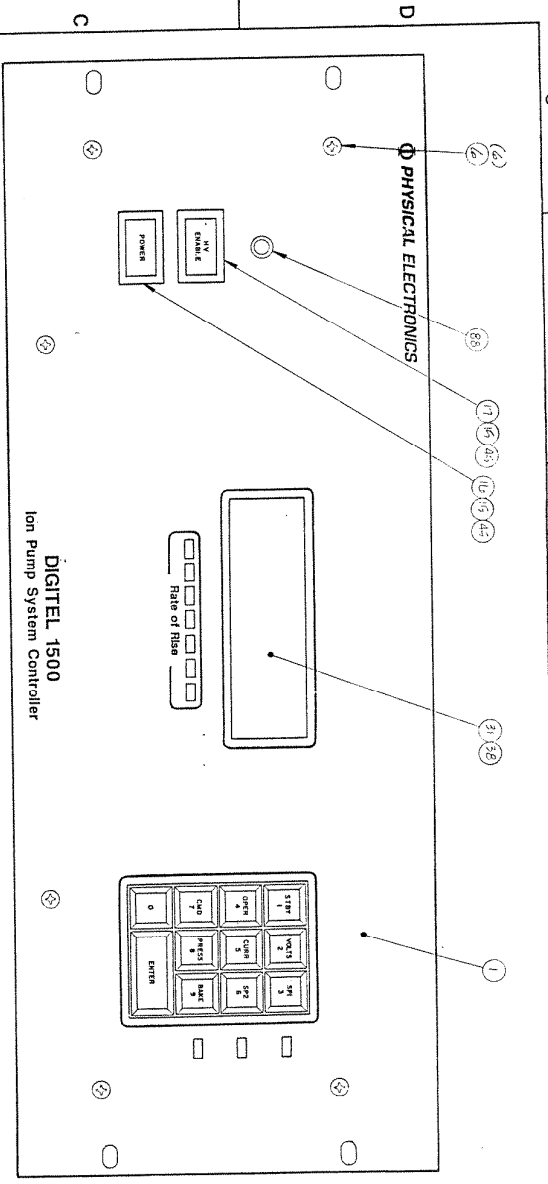

ITEM NO.	QUANTITY	DESCRIPTION	UNIT	REV.
1	1	Physical Electronics	PCB	1
2	1	Control - Digital	PCB	1
3	1	1500	PCB	1
4	1	222-1500	PCB	1
5	1	1500	PCB	1
6	1	222-1500	PCB	1
7	1	1500	PCB	1
8	1	222-1500	PCB	1
9	1	1500	PCB	1
10	1	222-1500	PCB	1
11	1	1500	PCB	1
12	1	222-1500	PCB	1
13	1	1500	PCB	1
14	1	222-1500	PCB	1
15	1	1500	PCB	1
16	1	222-1500	PCB	1
17	1	1500	PCB	1
18	1	222-1500	PCB	1
19	1	1500	PCB	1
20	1	222-1500	PCB	1
21	1	1500	PCB	1
22	1	222-1500	PCB	1
23	1	1500	PCB	1
24	1	222-1500	PCB	1
25	1	1500	PCB	1
26	1	222-1500	PCB	1
27	1	1500	PCB	1
28	1	222-1500	PCB	1
29	1	1500	PCB	1
30	1	222-1500	PCB	1
31	1	1500	PCB	1
32	1	222-1500	PCB	1
33	1	1500	PCB	1
34	1	222-1500	PCB	1
35	1	1500	PCB	1
36	1	222-1500	PCB	1
37	1	1500	PCB	1
38	1	222-1500	PCB	1
39	1	1500	PCB	1
40	1	222-1500	PCB	1
41	1	1500	PCB	1
42	1	222-1500	PCB	1
43	1	1500	PCB	1
44	1	222-1500	PCB	1
45	1	1500	PCB	1
46	1	222-1500	PCB	1
47	1	1500	PCB	1
48	1	222-1500	PCB	1
49	1	1500	PCB	1
50	1	222-1500	PCB	1
51	1	1500	PCB	1
52	1	222-1500	PCB	1
53	1	1500	PCB	1
54	1	222-1500	PCB	1
55	1	1500	PCB	1
56	1	222-1500	PCB	1
57	1	1500	PCB	1
58	1	222-1500	PCB	1
59	1	1500	PCB	1
60	1	222-1500	PCB	1
61	1	1500	PCB	1
62	1	222-1500	PCB	1
63	1	1500	PCB	1
64	1	222-1500	PCB	1
65	1	1500	PCB	1
66	1	222-1500	PCB	1
67	1	1500	PCB	1
68	1	222-1500	PCB	1
69	1	1500	PCB	1
70	1	222-1500	PCB	1
71	1	1500	PCB	1
72	1	222-1500	PCB	1
73	1	1500	PCB	1
74	1	222-1500	PCB	1
75	1	1500	PCB	1
76	1	222-1500	PCB	1
77	1	1500	PCB	1
78	1	222-1500	PCB	1
79	1	1500	PCB	1
80	1	222-1500	PCB	1
81	1	1500	PCB	1
82	1	222-1500	PCB	1
83	1	1500	PCB	1
84	1	222-1500	PCB	1
85	1	1500	PCB	1
86	1	222-1500	PCB	1
87	1	1500	PCB	1
88	1	222-1500	PCB	1
89	1	1500	PCB	1
90	1	222-1500	PCB	1
91	1	1500	PCB	1
92	1	222-1500	PCB	1
93	1	1500	PCB	1
94	1	222-1500	PCB	1
95	1	1500	PCB	1
96	1	222-1500	PCB	1
97	1	1500	PCB	1
98	1	222-1500	PCB	1
99	1	1500	PCB	1

SEE DETACHED PL.

ZONE	REV	DESCRIPTION	DATE	APPROVED
A	1	REL. EST. - CO 1270	11-28-57	
B	1	SEE ECO 6402	11-28-57	
C	1	SEE ECO 6453	11-28-57	
D	1	SEE ECO 6760	11-28-57	
E	1	SEE ECO 6781	11-28-57	
F	1	SEE ECO 6984	11-28-57	
G	1	SEE CO 9609/1	11-28-57	
H	1	SEE CO 9609/1	11-28-57	
I	1	SEE CO 1242 - CO 1241	11-28-57	
J	1	SEE CO 1242 - CO 1241	11-28-57	
K	1	SEE CO 1242 - CO 1241	11-28-57	
L	1	SEE CO 1242 - CO 1241	11-28-57	
M	1	SEE CO 1242 - CO 1241	11-28-57	
N	1	SEE CO 1242 - CO 1241	11-28-57	
O	1	SEE CO 1242 - CO 1241	11-28-57	

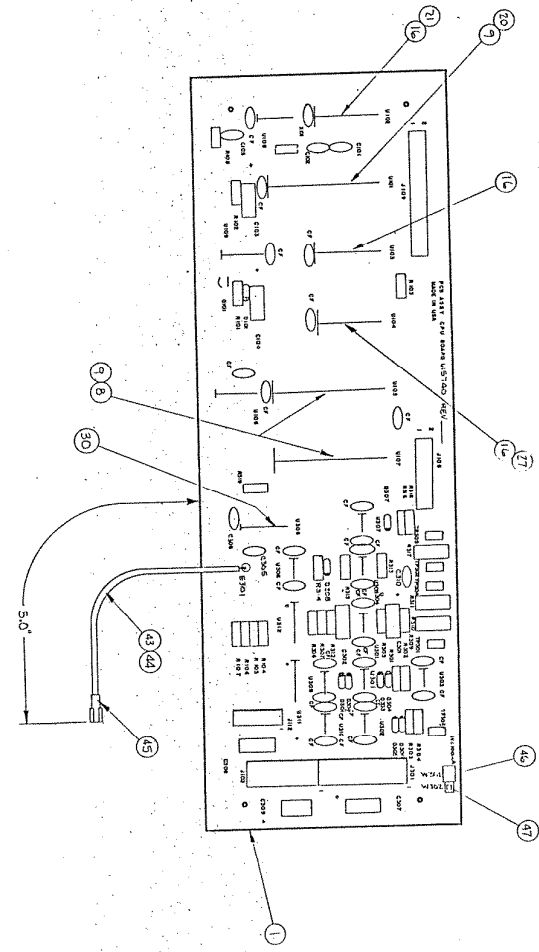

NOTE:
 △ MARK APPLICABLE REVISION IN SPACE PROVIDED.

REV	DATE	DESCRIPTION	BY	CHKD
1	11-28-57	REL. EST. - CO 1270		
2	11-28-57	SEE ECO 6402		
3	11-28-57	SEE ECO 6453		
4	11-28-57	SEE ECO 6760		
5	11-28-57	SEE ECO 6781		
6	11-28-57	SEE ECO 6984		
7	11-28-57	SEE CO 9609/1		
8	11-28-57	SEE CO 9609/1		
9	11-28-57	SEE CO 1242 - CO 1241		
10	11-28-57	SEE CO 1242 - CO 1241		
11	11-28-57	SEE CO 1242 - CO 1241		
12	11-28-57	SEE CO 1242 - CO 1241		
13	11-28-57	SEE CO 1242 - CO 1241		
14	11-28-57	SEE CO 1242 - CO 1241		
15	11-28-57	SEE CO 1242 - CO 1241		
16	11-28-57	SEE CO 1242 - CO 1241		
17	11-28-57	SEE CO 1242 - CO 1241		
18	11-28-57	SEE CO 1242 - CO 1241		
19	11-28-57	SEE CO 1242 - CO 1241		
20	11-28-57	SEE CO 1242 - CO 1241		
21	11-28-57	SEE CO 1242 - CO 1241		
22	11-28-57	SEE CO 1242 - CO 1241		
23	11-28-57	SEE CO 1242 - CO 1241		
24	11-28-57	SEE CO 1242 - CO 1241		
25	11-28-57	SEE CO 1242 - CO 1241		
26	11-28-57	SEE CO 1242 - CO 1241		
27	11-28-57	SEE CO 1242 - CO 1241		
28	11-28-57	SEE CO 1242 - CO 1241		
29	11-28-57	SEE CO 1242 - CO 1241		
30	11-28-57	SEE CO 1242 - CO 1241		
31	11-28-57	SEE CO 1242 - CO 1241		

8 7 6 5 4 3 2 1

8 7 6 5 4 3 2 1

8 7 6 5 4 3 2 1

8 7 6 5 4 3 2 1

ITEM	PART NO.	QTY	UM	DESCRIPTION	PART STATUS	REFERENCE/NOTES	FROM	TO
1	625461	1.000	EA	PCB-CPU,DIGITEL			012094	082394
2	625463	0.000	EA	SCHEM DIAG-CPU PCB,DIGITEL			010191	
2	615741	0.000	EA	SCHEM DIAG-CPU BD,DIGITAL 1500			082494	
3	171426	6.000	EA	D10-ZENER, 15V, 1W, 1N4744	PP	D301,302,303,304, 305,306	010101	
4	478126	1.000	EA	XSTR-2N3904,NPN,40V,.3M	PP	Q101	021489	
5	177253	2.000	EA	RES-1K OHM,.25W,5%,RC07	NP	R101,316	010101	
6	477157	29.000	EA	CAP-0.1UF,50V,20%,CER ML,RDL	NP	CF'S,C105,306	010101	
7	478028	5.000	EA	RES-10K OHM,.25W,5%,RC07	NP	R104-107,108	010101	
8	1002067	2.000	EA	IC-6821,PERIPH INTRFC ADAPTER	NP	U105,107	010101	
10	371104	5.000	EA	RES-10K OHM,.25W,1%,RN60D	PP	R301-304,309	010101	
11	371118	1.000	EA	RES-1M OHM,.25W,1%,RN60D	PP	R305	010101	
12	371108	4.000	EA	RES-100K OHM,.25W,1%,RN60D	PP	R307,313,314,315	010101	
13	603955	2.000	EA	D10-HS 5W,75V,1N914	PP	D101,308	021489	
14	1002141	5.000	EA	JACK-TEST POINT,BLUE	PP	TP301,305	010101	
15	1002152	2.000	EA	POT-10K,1.75W,1ST,PCB	PP	R311,317	010101	
16	275146	1.000	EA	SKT-IC,DIP,24P,.6W,TIN,L PRDF	PP	XU103	070993	
17	1002158	2.000	EA	CAP-27 PF,1KV,5%,CER DISC,RDL	NP	C101,102	010101	
18	1002159	6.000	EA	CAP-10 UF,50V,20%,ELECT,AXL	PP	C103,104,301,302, 307,309	010101	
19	279226	2.000	EA	RES-3.3K OHM,.25W,5%,RC07	NP	R102,103	010101	
20	1002162	1.000	EA	IC-6802,MPU,8 BIT	NP	U101	010101	
21	604613	1.000	EA	IC-74LS154,4-16 DECODE/DEMUX	NP	U102	010101	
22	1002168	1.000	EA	CRYSTAL-2.4576 MHZ,CY2B	PP	X101	010101	
23	279205	2.000	EA	RES-100 OHM,.25W,5%,RC07	NP	R305,312	010101	
24	611013	9.000	EA	IC-OP AMP,CA3140E,BIMOS	PP	U301-307,309,310	022189	
25	607382	1.000	EA	IC-74LS00,QUAD 2 INP NAND	NP	U108	010101	
26	1002287	2.000	EA	IC-4040,12-BIT BIN COUNTER	PP	U106,109	010101	
27	1002289	1.000	EA	IC-6810,SRAM,1K(128X8)	DU	U104	010101	
28	472028	1.000	EA	RES-4.99K OHM,.25W,1%,RN60D	PP	R318	010101	
29	608557	1.000	EA	D10-ZENER,6.2V,.4W,1N821	PP	D307	010101	
30	1003235	1.000	EA	IC-AD7574JN,ADC AD7574JN	PP	U308	010101	
31	1003236	1.000	EA	CAP-100 PF,100V,10%,CER ML,RDL	NP	C305	010101	
32	1003237	1.000	EA	POT-2K,1.75W,1ST,PCB	PP	R310	010101	
33	1003243	1.000	EA	CONN-.156C,9P,PCB,STR,1ROW,SN	NP	J301	010101	
34	1003245	1.000	EA	CONN-.100C,20P,PCB,RA,2ROW	NP	J108	010101	
35	1003246	1.000	EA	CONN-.100C,40P,PCB,RA,2ROW		J109	010101	
36	1003258	2.000	EA	IC-AD7510D1JN,ANLG SW,SPST,4X	PP	U311,312	010101	
37	177281	1.000	EA	CONN-.156C,5P,PCB,STR,1ROW,SN	PP	J112	060590	
38	279257	1.000	EA	RES-200K OHM,.25W,5%,RC07	NP	R319	010101	
39	602047	1.000	EA	CONN-.156C,7P,PCB,STR,1ROW,SN	PP	J102	060590	
			EA	CAP-1000UF,10V,20%,ELECT,AXL	NP	R308	010101	

PERKIN-ELMER SHEET: 2 8/24/94 PART STATUS 1 PART NUMBER 615740 REV P EFFECTIVITY DATES:

PHYSICAL ELEC. DIV. ASSY-PCB,CPU,DIGITEL 1500

TEM	PART NO.	QTY	UM	DESCRIPTION	PART STATUS	REFERENCE/NOTES	FROM	TO
42	278002	1.000	EA	CAP-0.01 UF,50V,20%,CER ML,RDL	PP	C310	031192	
43	570100	0.500	FT	CA-BRAID,FLAT,COPPER,.125W			100693	
44	506704	5.000	IN	TUBING-SHRK,.125ID,POLYOLE,BLK			012094	
45	603609	1.000	EA	LUG-QC,F.16-14GA,.25X.032,INS			012094	
46	627077	3.000	PC	CONN-.100C,50P,PCB,STR,BRKAWAY		XW301,302	012094	
47	623436	1.000	EA	CONN-.100C,25,SHUNT JUMPER,AU		XW302	012094	

** END OF REPORT **

PERKIN-ELMER PHYSICAL ELEC. DIV.		TITLE ASSY-PCB,PWR SPLY,DIGITEL		SHEET: 1 6/07/95		PART STATUS LEEB 30994 1		PART NUMBER 625702		REV B		EFFECTIVITY DATES:	
TEM	PART NO.	QTY	UM	DESCRIPTION	PART STATUS	PART STATUS	REFERENCE/NOTES	FROM	TO				
1	625701	1.000	EA	PCB-POWER SUPPLY			TP401,402,403	010191					
2	1002141	3.000	EA	JACK-TEST POINT,BLUE			U401	010191					
3	1002287	1.000	EA	IC-4040,12-BIT BIN COUNTER	PP		U402	010191					
4	623660	1.000	EA	OPTO ISOLATOR,MOC3012,TRIAC DR	PP		U403,404,405	010191					
5	1003303	3.000	EA	OPTO CPLR/ISOLATOR,2.5 KV,4N32	PP		VR401	010191					
6	372017	1.000	EA	V REG,+15V,1A,TO220, LM7815CT	PP		VR402	010191					
7	474025	1.000	EA	V REG,-15V,1A,TO220, LM7915CT	PP		VR403	010191					
8	1003663	1.000	EA	V REG,+5V,1A,TO3, LM340KC	PP		Q401,402,403	010191					
9	1002066	3.000	EA	XSTR-2N6427 ,DARL,NPN	PP		Q404,405	010191					
10	478126	2.000	EA	XSTR-2N3904 ,NPN, 40V, .3M	PP		D401,402,403,404,405,409,410	010191					
11	601321	6.000	EA	DIO-RECT ,200V,1A ,1N4003	NP	LEEB 31794	D405-408	010191					
12	1003268	4.000	EA	DIO-RECT ,50V ,3A ,1N5400	PP		D411,412	010191					
13	603955	2.000	EA	DIO-HS 5M ,75V, ,1N914	PP		D413	010191					
14	1002312	1.000	EA	DIO-ZENER, 3.3V, .5M ,1N5226B	PP		C401,402	010191					
15	479212	2.000	EA	CAP-1000 UF,35V,150/10%,EL,AXL	NP		C403	010191					
16	472034	1.000	EA	CAP-5000 UF,16V,150/10%,EL,AXL	NP		C404-409	010191					
17	617886	6.000	EA	CAP-0.1 UF,50V,20%,CER ML,RDL	PP		R401,413,415,417	010191					
18	603140	4.000	EA	RES-10K OHM, .12W, 1%,RN55D	PP		R402	010191					
19	603767	1.000	EA	RES-475 OHM, .12W, 1%,RN55D	PP		R403	010191					
20	609150	1.000	EA	RES-3.32K OHM, .12W, 1%,RC32	NP		R404	010191					
21	1003385	1.000	EA	RES-390 OHM, 1W , 5%, RN60D	PP		R405,407,408	010191					
22	173032	3.000	EA	RES-200 OHM, .25W, 1%,RN60D	PP		R406	010191					
23	606100	1.000	EA	RES-536 OHM, .25W, 1%,RN60D	PP		R409,412,414,416,418	010191					
24	371101	5.000	EA	RES-2K OHM, .25W, 1%,RN60D	PP		R410	010191					
25	603131	1.000	EA	RES-100 OHM, .12W, 1%,RN55D	PP		R411	010191					
26	1001036	1.000	EA	RES-402 OHM, .25W, 1%,RN60D	PP		DIG 500: W401,403	010191					
28	378079	2.000	EA	RES-ZEROHM,MOLDED JUMPER WIRE	PP		DIG 1500: W402,404	010191					
29	1003239	2.000	EA	CONN-.156C, 7P,PCB,RA ,1ROW,SN	PP		J402,407	010191					
30	1003266	1.000	EA	CONN-.156C,11P,PCB,RA ,1ROW,SN	PP		J403	010191					
31	177050	1.000	EA	CONN-.156C,10P,PCB,STR,1ROW,SN	NP			091693					
32	377091	2.000	EA	CONN-.156C, 6P,PCB,STR,1ROW,SN	PP			091693					
33	1003326	1.000	EA	RLY-PNL ,DPDT, 12VDC,10A/240V			K401	010191					
34	601850	1.000	EA	CLIP-COMPONENT,1.000 DIA.				010191					
35	171300	2.000	EA	FUSE-3AG, .50A,250V SLD BLD			F401,402	010191					
36	613833	2.000	EA	HT SK-TO220,VERT MT W/TABS			XVR401,402	010191					
37	1004672	2.000	EA	INSULATOR-HEATSINK PAD,TD-220			XVR401,402	010191					
38	601807	1.000	EA	HT SK-TO3,TOP FLG MTG, S427			XVR403	010191					
39	625522	1.000	EA	HT SK-TO3,W/D STUD,6016B			XVR403	010191					
40	1002812	1.000	EA	INSULATOR-MTG PAD,TD-3 CASE			XVR403	010191					
41	505400	2.000	EA	WSHR-PDP RIVET, .375X.125, STL				010191					

REV	DATE	BY	DESCRIPTION
7570		A	SEE ECO
8760		B	SEE ECO
9688		C	SEE CO
9758		D	SEE CO

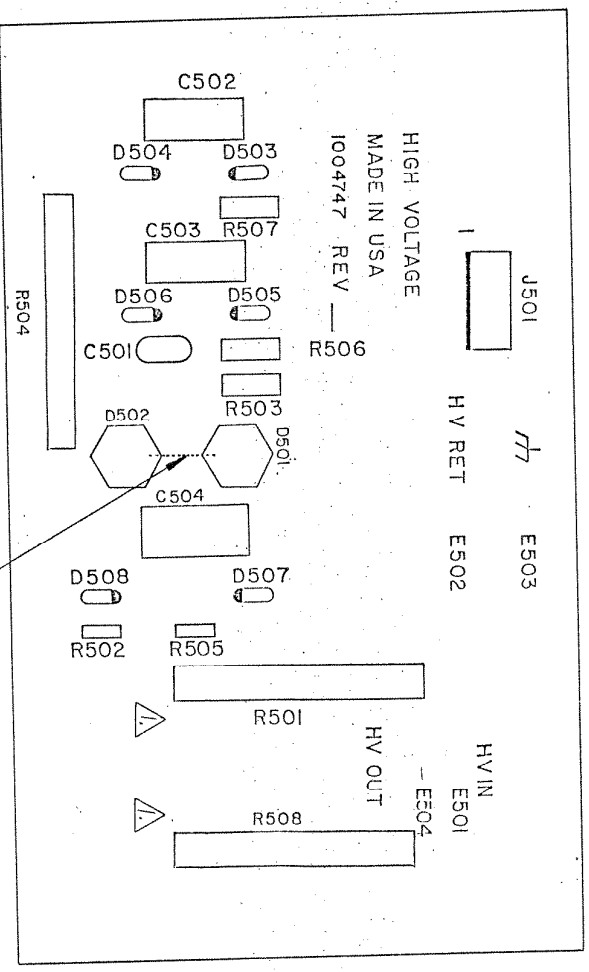

NOTES:
 1. MOUNT R501 AND R508 1/4 INCH OFF THE P.C. BOARD.

SEE DETACHED P/L

ITEM #	QTY	DESCRIPTION
1	1	P.C.B. Pkg. H.W. Board
2	2	Resistor, 12 1/2 W
3	6	Diode 200V, 1A 1W
4	1	Res. 50K 1/2 W
5	1	Cap. 1000 P.F. 50V
6	1	Cap. 1000 P.F. 50V
7	1	Cap. 1000 P.F. 50V
8	1	Cap. 1000 P.F. 50V
9	1	Cap. 1000 P.F. 50V
10	1	Cap. 1000 P.F. 50V
11	1	Cap. 1000 P.F. 50V
12	1	Cap. 1000 P.F. 50V
13	1	Cap. 1000 P.F. 50V
14	1	Cap. 1000 P.F. 50V

Designation	ITEM	SZ	PART NUMBER	QTY	U/M	DESCRIPTION
Q501	M.E.T.	10A	10A-29-95			Vacuum Products • Eden Prairie, Minn. 55344
Q502	M.E.T.	10A	10A-29-95			
Q503	M.E.T.	10A	10A-29-95			
Q504	M.E.T.	10A	10A-29-95			
Q505	M.E.T.	10A	10A-29-95			
Q506	M.E.T.	10A	10A-29-95			
Q507	M.E.T.	10A	10A-29-95			
Q508	M.E.T.	10A	10A-29-95			
Q509	M.E.T.	10A	10A-29-95			
Q510	M.E.T.	10A	10A-29-95			
Q511	M.E.T.	10A	10A-29-95			
Q512	M.E.T.	10A	10A-29-95			
Q513	M.E.T.	10A	10A-29-95			
Q514	M.E.T.	10A	10A-29-95			
Q515	M.E.T.	10A	10A-29-95			
Q516	M.E.T.	10A	10A-29-95			
Q517	M.E.T.	10A	10A-29-95			
Q518	M.E.T.	10A	10A-29-95			
Q519	M.E.T.	10A	10A-29-95			
Q520	M.E.T.	10A	10A-29-95			
Q521	M.E.T.	10A	10A-29-95			
Q522	M.E.T.	10A	10A-29-95			
Q523	M.E.T.	10A	10A-29-95			
Q524	M.E.T.	10A	10A-29-95			
Q525	M.E.T.	10A	10A-29-95			
Q526	M.E.T.	10A	10A-29-95			
Q527	M.E.T.	10A	10A-29-95			
Q528	M.E.T.	10A	10A-29-95			
Q529	M.E.T.	10A	10A-29-95			
Q530	M.E.T.	10A	10A-29-95			
Q531	M.E.T.	10A	10A-29-95			
Q532	M.E.T.	10A	10A-29-95			
Q533	M.E.T.	10A	10A-29-95			
Q534	M.E.T.	10A	10A-29-95			
Q535	M.E.T.	10A	10A-29-95			
Q536	M.E.T.	10A	10A-29-95			
Q537	M.E.T.	10A	10A-29-95			
Q538	M.E.T.	10A	10A-29-95			
Q539	M.E.T.	10A	10A-29-95			
Q540	M.E.T.	10A	10A-29-95			
Q541	M.E.T.	10A	10A-29-95			
Q542	M.E.T.	10A	10A-29-95			
Q543	M.E.T.	10A	10A-29-95			
Q544	M.E.T.	10A	10A-29-95			
Q545	M.E.T.	10A	10A-29-95			
Q546	M.E.T.	10A	10A-29-95			
Q547	M.E.T.	10A	10A-29-95			
Q548	M.E.T.	10A	10A-29-95			
Q549	M.E.T.	10A	10A-29-95			
Q550	M.E.T.	10A	10A-29-95			
Q551	M.E.T.	10A	10A-29-95			
Q552	M.E.T.	10A	10A-29-95			
Q553	M.E.T.	10A	10A-29-95			
Q554	M.E.T.	10A	10A-29-95			
Q555	M.E.T.	10A	10A-29-95			
Q556	M.E.T.	10A	10A-29-95			
Q557	M.E.T.	10A	10A-29-95			
Q558	M.E.T.	10A	10A-29-95			
Q559	M.E.T.	10A	10A-29-95			
Q560	M.E.T.	10A	10A-29-95			
Q561	M.E.T.	10A	10A-29-95			
Q562	M.E.T.	10A	10A-29-95			
Q563	M.E.T.	10A	10A-29-95			
Q564	M.E.T.	10A	10A-29-95			
Q565	M.E.T.	10A	10A-29-95			
Q566	M.E.T.	10A	10A-29-95			
Q567	M.E.T.	10A	10A-29-95			
Q568	M.E.T.	10A	10A-29-95			
Q569	M.E.T.	10A	10A-29-95			
Q570	M.E.T.	10A	10A-29-95			
Q571	M.E.T.	10A	10A-29-95			
Q572	M.E.T.	10A	10A-29-95			
Q573	M.E.T.	10A	10A-29-95			
Q574	M.E.T.	10A	10A-29-95			
Q575	M.E.T.	10A	10A-29-95			
Q576	M.E.T.	10A	10A-29-95			
Q577	M.E.T.	10A	10A-29-95			
Q578	M.E.T.	10A	10A-29-95			
Q579	M.E.T.	10A	10A-29-95			
Q580	M.E.T.	10A	10A-29-95			
Q581	M.E.T.	10A	10A-29-95			
Q582	M.E.T.	10A	10A-29-95			
Q583	M.E.T.	10A	10A-29-95			
Q584	M.E.T.	10A	10A-29-95			
Q585	M.E.T.	10A	10A-29-95			
Q586	M.E.T.	10A	10A-29-95			
Q587	M.E.T.	10A	10A-29-95			
Q588	M.E.T.	10A	10A-29-95			
Q589	M.E.T.	10A	10A-29-95			
Q590	M.E.T.	10A	10A-29-95			
Q591	M.E.T.	10A	10A-29-95			
Q592	M.E.T.	10A	10A-29-95			
Q593	M.E.T.	10A	10A-29-95			
Q594	M.E.T.	10A	10A-29-95			
Q595	M.E.T.	10A	10A-29-95			
Q596	M.E.T.	10A	10A-29-95			
Q597	M.E.T.	10A	10A-29-95			
Q598	M.E.T.	10A	10A-29-95			
Q599	M.E.T.	10A	10A-29-95			
Q600	M.E.T.	10A	10A-29-95			

PERKIN-ELMÉR
 Vacuum Products • Eden Prairie, Minn. 55344
 PCB ASSY. H. V. BOARD
 DIGITAL 1500
 DRAWING NO 1004747
 SHEET 1 OF 1

PERKIN-ELMER SHEET: 1 11/06/90 PART NUMBER 1004747 ENG. DWG NO/REV 1D EFFECTIVITY DATES: FROM TO

PHYSICAL ELEC. DIV. BOARD ASSY-H,V,PROCESSOR 1500

ITEM	PART NO.	QTY	UM	DESCRIPTION	DRAWING NO.	REFERENCE	FROM	TO
0001	1004740	1.000	EA	PCB-FAB H.V. PROCESSOR 1500				
0002	1004776	.000	EA	SCHEMATIC H.V. PROCESSOR 1500				
0003	1000554	2.000	EA	RES- 20 MOHM, 4W ,1%,15.5KV		R501,508		
0004	171426	6.000	EA	DID-ZENER,15V ,1W ,1N4744		D503-508	121587	
0005	620196	3.000	EA	RES- 47.5 KOHM, .12W, 1%,RN55D		R505-507	83090	
0006	275016	1.000	EA	RES- 6.04KOHM, .25W, 1%,RN60D		R502	121587	
0007	373035	1.000	EA	CAP-UF, .1 ,100 V ,CER ,RDL	DU	C501		
0008	1004777	2.000	EA	DID-ZENER, 6.2V,10W ,1N3998A		D501,502		
0009	1003275	3.000	EA	CAP-UF, 10, 15 VDC,NP ,AXL		C502-504	60590	
0010	177049	1.000	EA	CONN-STR PIN LOCK HDR, 4 CKT		J501		
0011	615710	1.000	EA	RES- 3 OHM,10W , 1%,RS-10		R504	121587	
0012	371091	1.000	EA	RES- 3.01KOHM, .25W, 1%,RN60D		R503	21489	
0013	533225	2.000	EA	NUT-KEPS,10-32,HEX,SST		D501,502		
0014	501700	1.000	FT	WIRE-BARE,SOLID,TND COP 22GA				

** END OF REPORT **

8
7
6
5
4
3
2
1

8
7
6
5
4
3
2
1

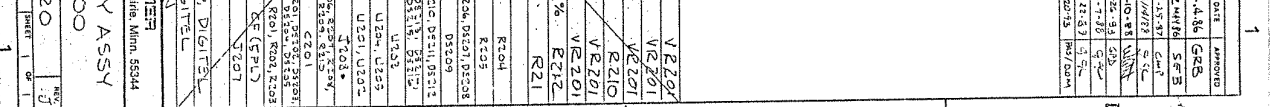
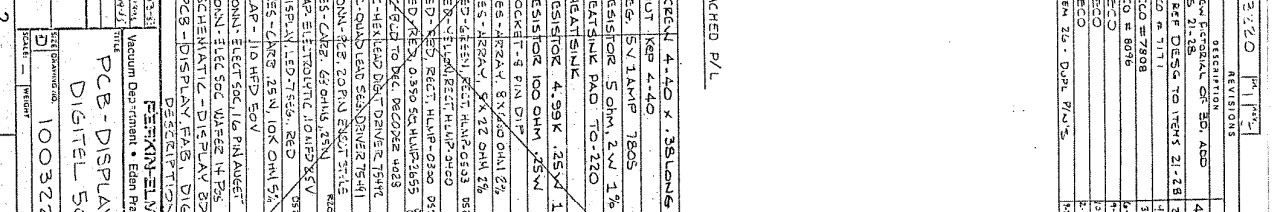
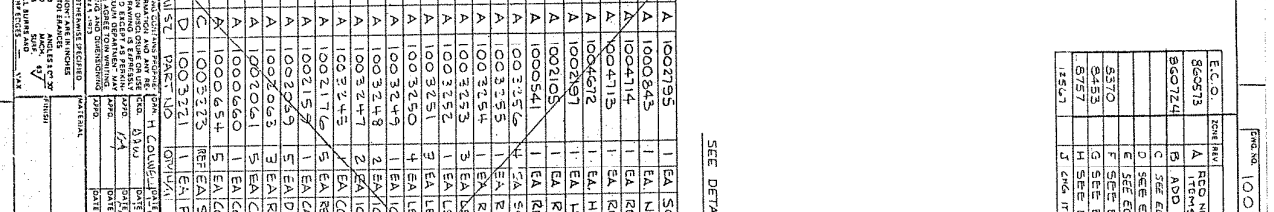
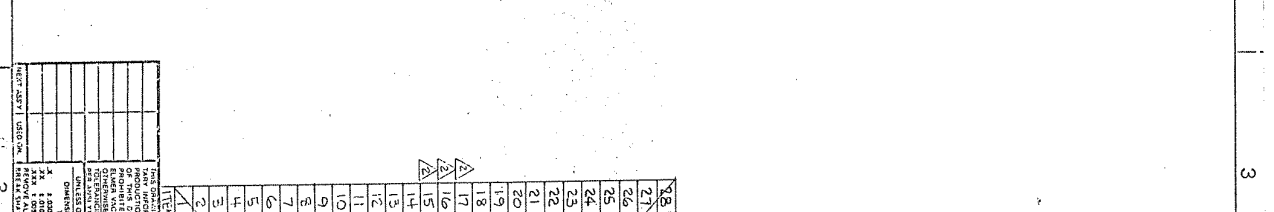
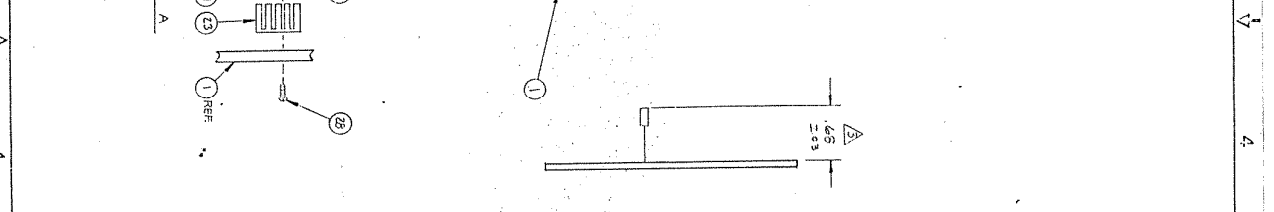
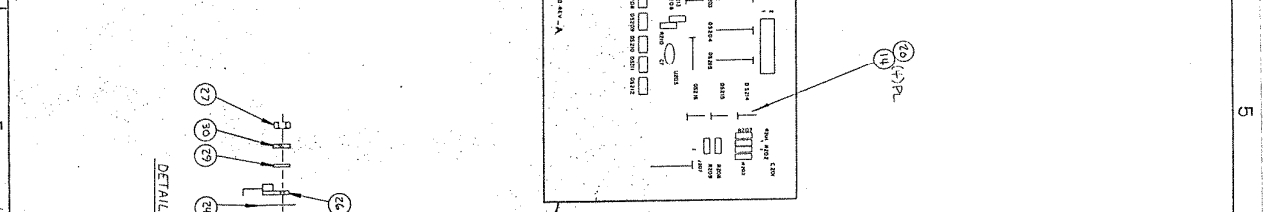
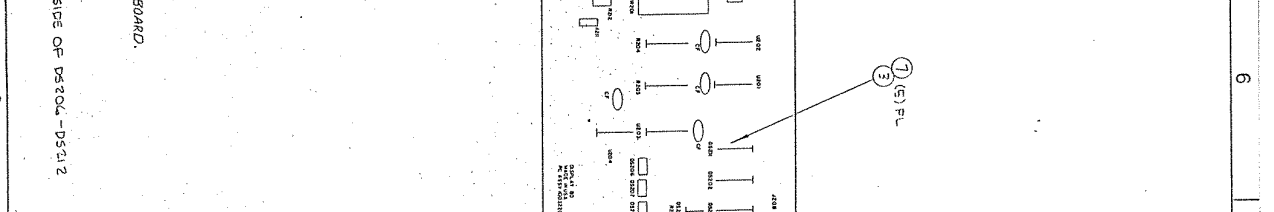
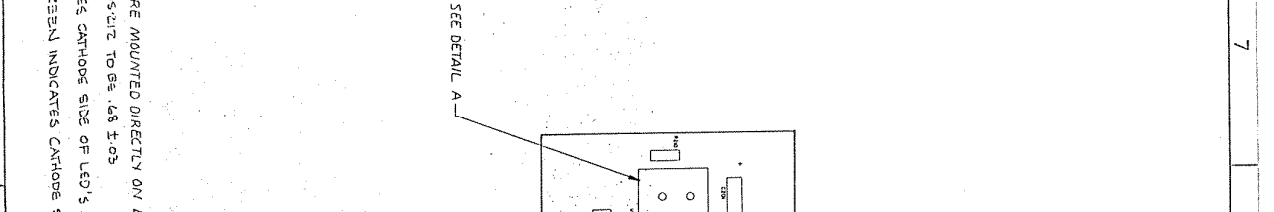

REV	DESCRIPTION	DATE	APPROVED
1	PCB DISPLAY ASSY	1003220	
2	DIGITAL 500		
3			
4			
5			
6			
7			
8			

NOTES:
 1 THICK LINE ON SILKSCREEN INDICATES CATHODE SIDE OF LED'S.
 2 SHORT LEAD INDICATES CATHODE SIDE OF LED'S.
 3 HEIGHT OF D5206 - D5212 TO BE .48 ± .03
 4 U201, 202, 204, 205 ARE MOUNTED DIRECTLY ON BOARD.

PERKIN-ELMER SHEET: 1 7/13/94 PART STATUS 1 PART NUMBER 1003220 REV J EFFECTIVITY DATES:

PHYSICAL ELEC. DIV. ASSY-PCB, DISPLAY, DIGITEL 500 LEEB 31694 1 1003220

TEM	PART NO.	QTY	UM	DESCRIPTION	PART STATUS	REFERENCE/NOTES	FROM	TO
1	1003221	1.000	EA	PCB-DISPLAY, DIGITEL 500/1500			010101	
2	1003223	0.000	EA	SCHEM DIAG-DISPLAY BD, DIGITEL			010101	
3	171416	5.000	EA	SKT-IC, DIP, 14P, .3M, TIN, L PRODF	PP	J207	010488	
4	378029	1.000	EA	SKT-IC, DIP, 16P, .3M, TIN, L PRODF	NP	CF'S	010191	
5	477157	5.000	EA	CAP-0.1 UF, 50V, 20%, CER ML, RDL	NP	R201-203	083088	
6	478028	3.000	EA	RES-10K OHM, .25W, 5%, RCO7	NP	DS201 THRU DS 205	010101	
7	1002069	5.000	EA	DISPLAY-LED, 7 SEG, HP 5082-7760	PP	C201	010101	
8	1002159	1.000	EA	CAP-10 UF, 50V, 20%, ELECT, AXL	NP	R206-210	021489	
9	279203	5.000	EA	RES-68 OHM, .25W, 5%, RCO7	NP	J208	010101	
10	1003245	1.000	EA	CONN-.100C, 20P, PCB, RA, 2RDM	NP	U201, 202	010101	
11	1003247	2.000	EA	IC-QUAD LED DRVR, SN75491N	NP	U204, 205	010101	
12	1003248	2.000	EA	IC-HEX, LED DRVR, DS75492N	NP	U203	010101	
13	478005	1.000	EA	IC-4028, BCD/DEC DECODER	PP	DS213, 214, 215, 216	010101	
14	1003250	4.000	EA	DIO-LED, RED LIGHTBAR, .350" SQ.		DS210, 211, 212, SEE	010101	
15	378048	3.000	EA	DIO-LED, RECTANGULAR, RED		NOTE 2	030188	
16	1003252	1.000	EA	DIO-LED, 2V/20MA, YEL, HLMP-0401		DS209, SEE NOTE 2	010101	
17	1003253	3.000	EA	DIO-LED, 2V/20MA, GRN, HLMP-0504		DS206, 207, 208, SEE	010101	
18	1003254	1.000	EA	RES NTWK-22, DIP, BI, .25W, 2%	PP	NOTE 2	010101	
19	1003255	1.000	EA	RES NTWK-680, DIP, BI, .25W, 2%	PP	R204	010101	
20	272049	4.000	EA	SKT-IC, DIP, 8P, .3M, TIN, L PRODF	PP	R211	010101	
21	1000541	1.000	EA	RES-100 OHM, .25W, 1%, RN60D	PP	R212	010101	
22	472028	1.000	EA	RES-4.99K OHM, .25W, 1%, RN60D	PP	VR201	010101	
23	1002197	1.000	EA	HT SK-2 PLST SEMICONND, 290-2AB		VR201	010101	
24	1004672	1.000	EA	INSULATOR-HEATSINK PAD, TO-220		VR201	010101	
25	1004713	1.000	EA	RES-5 OHM, 1W, 1% WM	PP	R213	010101	
26	472037	1.000	EA	V REG, +5V, 1A, TO220, LM7805CT	PP	VR201	091093	
27	542104	1.000	EA	NUT-HEX, SM PATT, # 4-40, SST		VR201	081187	071094
27	1000843	1.000	EA	NUT-KEPS, # 4-40, SST		VR201	071194	071094
28	541806	1.000	EA	SCR-PAN, 4-40X .375, PHHD, SST		VR201	081187	071094
28	541808	1.000	EA	SCR-PAN, 4-40X .500, PHHD, SST			071194	
29	512004	1.000	EA	WSHR-FLT, # 4, .250X.125X.02, SST			081187	071094
30	542204	1.000	EA	WSHR-SPLIT LOCK, # 4, SST			081187	071094

** END OF REPORT **

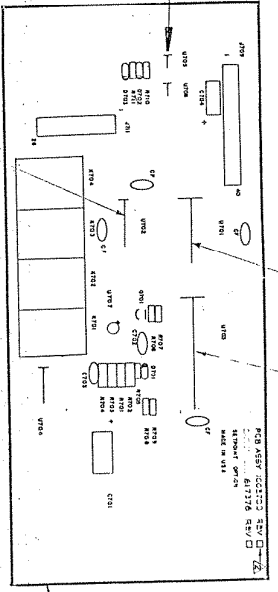

NOTES:
 1. CLIP PIN #6 OF U106 AND U106 BEFORE INSERTING INTO PCB.
 2. MARK REVISION LEVEL OF APPLICABLE ASSY IN BOX.

REV	DATE	DESCRIPTION	BY	APPROVED
1	10/22/01	INITIAL RELEASE
2	11/15/01
3	12/01/01
4	01/15/02
5	02/01/02
6	03/01/02
7	04/01/02
8	05/01/02
9	06/01/02
10	07/01/02
11	08/01/02
12	09/01/02
13	10/01/02
14	11/01/02
15	12/01/02
16	01/01/03
17	02/01/03
18	03/01/03
19	04/01/03
20	05/01/03
21	06/01/03
22	07/01/03
23	08/01/03
24	09/01/03
25	10/01/03
26	11/01/03
27	12/01/03
28	01/01/04
29	02/01/04
30	03/01/04
31	04/01/04
32	05/01/04
33	06/01/04
34	07/01/04
35	08/01/04
36	09/01/04
37	10/01/04
38	11/01/04
39	12/01/04
40	01/01/05
41	02/01/05
42	03/01/05
43	04/01/05
44	05/01/05
45	06/01/05
46	07/01/05
47	08/01/05
48	09/01/05
49	10/01/05
50	11/01/05
51	12/01/05
52	01/01/06
53	02/01/06
54	03/01/06
55	04/01/06
56	05/01/06
57	06/01/06
58	07/01/06
59	08/01/06
60	09/01/06
61	10/01/06
62	11/01/06
63	12/01/06
64	01/01/07
65	02/01/07
66	03/01/07
67	04/01/07
68	05/01/07
69	06/01/07
70	07/01/07
71	08/01/07
72	09/01/07
73	10/01/07
74	11/01/07
75	12/01/07
76	01/01/08
77	02/01/08
78	03/01/08
79	04/01/08
80	05/01/08
81	06/01/08
82	07/01/08
83	08/01/08
84	09/01/08
85	10/01/08
86	11/01/08
87	12/01/08
88	01/01/09
89	02/01/09
90	03/01/09
91	04/01/09
92	05/01/09
93	06/01/09
94	07/01/09
95	08/01/09
96	09/01/09
97	10/01/09
98	11/01/09
99	12/01/09
100	01/01/10

SEE DETACHED P/L

REV	DATE	DESCRIPTION	BY	APPROVED
1	10/22/01	INITIAL RELEASE
2	11/15/01
3	12/01/01
4	01/15/02
5	02/01/02
6	03/01/02
7	04/01/02
8	05/01/02
9	06/01/02
10	07/01/02
11	08/01/02
12	09/01/02
13	10/01/02
14	11/01/02
15	12/01/02
16	01/01/03
17	02/01/03
18	03/01/03
19	04/01/03
20	05/01/03
21	06/01/03
22	07/01/03
23	08/01/03
24	09/01/03
25	10/01/03
26	11/01/03
27	12/01/03
28	01/01/04
29	02/01/04
30	03/01/04
31	04/01/04
32	05/01/04
33	06/01/04
34	07/01/04
35	08/01/04
36	09/01/04
37	10/01/04
38	11/01/04
39	12/01/04
40	01/01/05
41	02/01/05
42	03/01/05
43	04/01/05
44	05/01/05
45	06/01/05
46	07/01/05
47	08/01/05
48	09/01/05
49	10/01/05
50	11/01/05
51	12/01/0			

PERKIN-ELMER PHYSICAL ELEC. DIV. TITLE SHEET: 1 3/09/93 PART STATUS 1 PART NUMBER 1003200 REV S EFFECTIVITY DATES:

PCB ASSY-SETPPOINT, DIGITEL 500 PCB ASSY-SETPPOINT, DIGITEL 500

TEM	PART NO.	QTY	UM	DESCRIPTION	PART STATUS	REFERENCE/NOTES	FROM	TO
1	1003201	1.000	EA	PCB-SETPPOINT, DIGITEL 500			010101	
2	1003203	0.000	EA	SCHEMATIC-SETPPOINT, DIGITEL			010101	
3	601321	3.000	EA	DID-RECT , 200V, 1A , 1N4003	NP	D701-703	080792	
4	617886	6.000	EA	CAP-0.1 UF, 50V, 20%, CER ML, RDL	PP	CF'S, C702, 703	041690	
5	603140	4.000	EA	RES-10K OHM, .12W, 1%, RN55D	PP	R706, 707, 710, 711	041690	
6	1002067	1.000	EA	IC-6821, PERIPH INTRFC ADAPTER	NP	U703	010101	
7	177069	1.000	EA	SKT-IC, DIP, 40P, .6W, TIN, L PRODF	PP	XU703	010101	030793
8	472028	1.000	EA	RES-4.99K OHM, .25W, 1%, RN60D	PP	R702	010101	
9	371091	1.000	EA	RES-3.01K OHM, .25W, 1%, RN60D	PP	R701	021489	
10	179313	1.000	EA	XSTR-2N3906 , PNP, 40V, .6W	PP	Q701	022189	
11	275146	1.000	EA	SKT-IC, DIP, 24P, .6W, TIN, L PRODF	PP	XU701	102091	
12	1002159	1.000	EA	CAP-10 UF, 50V, 20%, ELECT, AXL	PP	C704	010101	
13	609150	2.000	EA	RES-3.32K OHM, .12W, 1%, RN55D	PP	R708, 709	041690	
14	371107	2.000	EA	RES-49.9K OHM, .25W, 1%, RN60D	PP	R703, 704	010101	
15	373107	1.000	EA	CAP-100 UF, 25V, 20%, ELECT, AXL	PP	C701	111091	
16	1002333	1.000	EA	IC-OP AMP, CA3130S, T05 DIP FORM		U707	010101	
17	603584	1.000	EA	RES-200 OHM, .12W, 1%, RN55D	PP	R705	041690	
18	1003500	4.000	EA	RLY-PCB , SPDT, 12VDC, 3A/115V		K701, 702, 703, 704	010101	
19	1003246	1.000	EA	CONN-.100C, 40P, PCB, RA , 2ROW		J709	010101	
20	1003298	1.000	EA	CONN-.100C, 26P, PCB, STR, 2ROW		J711	010101	
21	1003301	1.000	EA	IC-2210, EEPROM, 64X4 BIT	NP	U702	010101	
22	1003302	1.000	EA	XSTR-MC1413 , ARRAY, NPN	PP	U704	010101	

REV	DATE	DESCRIPTION	BY	CHKD
A	07-91	RELEASE FOR PROD. 10825	BBB	
B	07-93	017 ITEM 10 CO#12203	PSE/DBM	
C	02-93	CO#12286	RLT/DBM	
D	08-93	CO#12424	PKA/DBM	
E	07-93	CO#12477	PKA/DBM	
F	10-94	REVERSED LABELS CO # 13448	CE/DBM	
G	11-94	CHKG STRAP VER. CO13520	ESB/DBM	
H	11-94	CHK LG 330 - CO 13532	KV/DBM	

NOTES:
 1. STAMP REVISION OF THIS DOCUMENT IN SPACE PROVIDED.
 2. LOOP BRAIDED CABLE FROM TOP OF BOARD THROUGH STRAIN RELIEF AND THEN THROUGH E100 FROM BACK OF BOARD. SOLDER AT E100.
 3. J814 - J815 REQUIRE 6 PINS EACH OF PART NUMBER 627077.

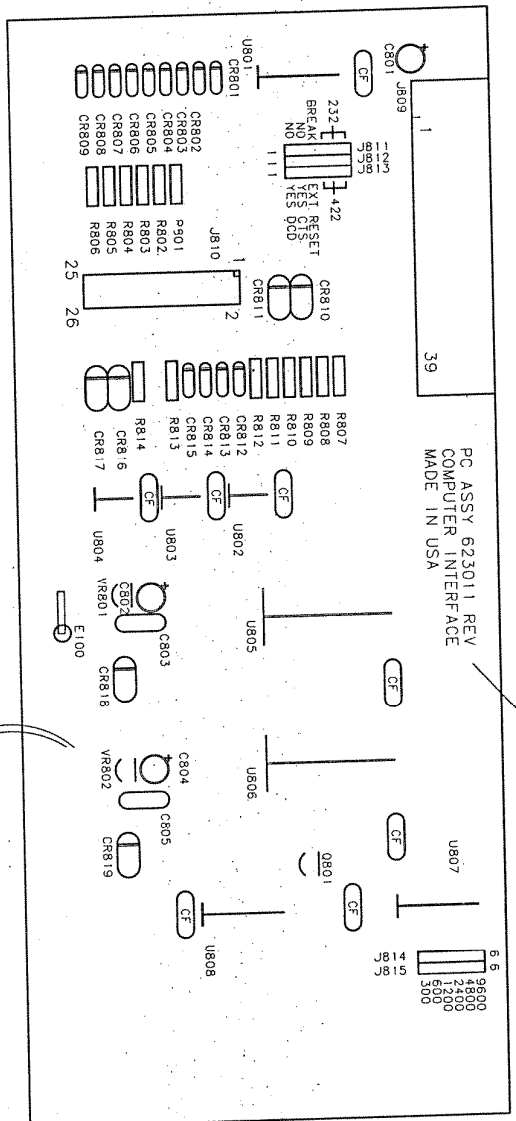

SEE DETACHED PARTS LIST

COMPUTER GENERATED		DATE	07-91	BY		BBB
TOLERANCES AND DIMENSIONS		SCALE	1:1	DRAWN		BBB
SHALL BE PARTS FROM		DATE		CHECKED		
UNLESS OTHERWISE SPECIFIED		DATE		APPROVED		
DIMENSIONS ARE IN INCHES		DATE		DESIGNED		
DIMENSIONS ARE IN MILLIMETERS		DATE		DRAWN		
TOLERANCES		DATE		CHECKED		
X .1/-0.00		DATE		APPROVED		
XX .005/-0.00		DATE		DESIGNED		
XXX .010/-0.00		DATE		DRAWN		
ANGLES		DATE		CHECKED		
4/-0.00		DATE		APPROVED		
4/-1 DEC		DATE		DESIGNED		
XX .010		DATE		DRAWN		
XXX .010		DATE		CHECKED		
DRAWING NUMBER		623011		SCALE		NONE
PART		H		REV		1

PERKIN-ELMER SHEET: 1 11/15/94
 PHYSICAL ELEC. DIV. ASSY-PCB, CMPTR INTFC PART STATUS 1
 LEEB 30994

TITLE PCB-CMPTR INTFC, RS232/442
 REVISION H

PART NUMBER 623011
 EFFECTIVITY DATES: FROM TO

ITEM	PART NO.	QTY	UM	DESCRIPTION	PART STATUS	REFERENCE/NOTES	REV	EFFECTIVITY DATES:
1	623010	1.000	EA	PCB-CMPTR INTFC, RS232/442	PP	UB07, 808		010101
2	1002287	2.000	EA	IC-4040, 12-BIT BIN COUNTER	NP	UB06		010101
3	1002288	1.000	EA	IC-6850, ASYNC COMM INTFC ADPTR	NP	UB03		010101
4	1002290	1.000	EA	IC-75150, LINE DVR, DUAL	NP	UB01		010101
5	1002291	1.000	EA	IC-75154, LINE RCVR, QUAD	PP	VRB01		010101
7	608639	1.000	EA	V REG, -12V, .1A, T092, MC79L12ACP	NP	VRB02		010101
8	1003382	1.000	EA	V REG, +12V, .1A, T092, 78L12A	PP	UB02, 804		010101
9	623017	2.000	EA	IC-75176B, DIFF BUS XCVR, RS422	PP	R806		011993
10	603131	1.000	EA	RES-100 OHM, .12W, 1%, RNS5D	PP	R807, 814		010101
11	602947	2.000	EA	RES-121 OHM, .12W, 1%, RNS5D	PP	R808, 809		010101
12	603137	2.000	EA	RES-4.99K OHM, .12W, 1%, RNS5D	PP	R805		010101
13	603140	1.000	EA	RES-10K OHM, .12W, 1%, RNS5D	PP	R801-803, 812, 813		010101
14	603767	5.000	EA	RES-475 OHM, .12W, 1%, RNS5D	PP	R810, 811		010101
15	604347	2.000	EA	RES-49.9K OHM, .12W, 1%, RNS5D	PP	R804		010101
16	609147	1.000	EA	RES-866 OHM, .12W, 1%, RNS5D	PP	CF'S, C803, C805		010101
17	617886	10.000	EA	CAP-0.1 UF, 50V, 20%, CER ML, RDL	PP	C801, 802, 804		010101
18	601279	3.000	EA	CAP-10 UF, 25V, 20%, TANT, RDL	PP	CR801-806, 808, 809,		010101
20	603955	12.000	EA	DIO-HS SW, 75V, .1N914	PP	812-815		010101
21	476179	2.000	EA	TRANSORB- 15V, SW, MPT-15	PP	CR818, 819		010101
22	278010	4.000	EA	TRANSORB- 8V, SW, MPT-8	PP	CR810, 811, 816, 817		010101
24	606772	1.000	EA	DIO-ZENER, 4.7V, .4W, 1N750A	PP	CR807		010101
25	478126	1.000	EA	XSTR-2N3904, NPN, 40V, .3W	PP	Q801		010101
26	1003246	1.000	EA	CONN-.100C, 40P, PCB, RA, 2ROW	PP	J809		010101
27	1003298	1.000	EA	CONN-.100C, 26P, PCB, STR, 2ROW		J810		010101
29	506704	9.000	IN	TUBING-SHRK, .125ID, POLYOLE, BLK				021494
30	570100	0.920	FT	CA-BRAID, FLAT, COPPER, .125W				110994
31	603609	1.000	EA	LUG-QC, F, 16-14GA, .25X.032, INS				091593
32	623436	7.000	EA	CONN-.100C, 2S, SHUNT JUMPER, AU	PP			010101
33	627077	30.000	PC	CONN-.100C, 50P, PCB, STR, BRKAWAY	PP			061193
36	275146	1.000	EA	SKT-IC, DIP, 24P, .6W, TIN, L PROF	PP	XUB05		030893
39	573710	1.000	EA	BAG-STATIC SHIELDING, 7X15 IN				030893

** END OF REPORT **